



Operation manual

CHV190 series special inverter for crane



Contents

Contents	1
SAFETY PRECAUTIONS	4
1. INTRODUCTION.....	5
1.1 Technology Features	5
1.2 Description of Nameplate.....	6
1.3 Selection Guide	6
1.4 Parts Description	8
1.5 Description of Extension Card	9
2. UNPACKING INSPECTION.....	10
3. DISASSEMBLE AND INSTALLATION	11
3.1 Environmental Requirement	11
4. INSTALLATION AND COMMISSIONING	13
4.1 Connections of Peripheral Devices	14
4.2 Terminal configuration	15
4.3 Typical Wiring Diagram	17
4.4 Wiring the Main Circuits	18
4.5 Wiring Control Circuit Terminals	20
4.6 Installation Guideline to EMC Compliance	22
5. OPERATION	26
5.1 Operating Keypad Description	26
5.2 Operation Process.....	28
5.3 Running State	30
6. DETAILED FUNCTION DESCRIPTION.....	32
6.1 P0 Group--Basic Function.....	32
6.2 P1 Group--Speed Curve.....	39
6.3 P2 Group--Motor Parameters	43
6.4 P3 Group--Vector Control	47
6.5 P4 Group--Encoder	52
6.6 P5 Group--Input Terminals	53
6.7 P6 Group--Output Terminals	59
6.8 P7 Group--Display Interface	64
6.9 P8 Group--Enhanced Function	69
6.10 P9 Group--Protection Parameters	79
6.11 PA Group--Serial Communication	84

6.12 Pb Group--Master-Slave Control Group.....	88
6.13 PC Group--Motor Parameters 1.....	96
6.14 Pd Group--Profibus Communication.....	100
6.15 PE Group--Factory Setting.....	104
6.16 PF Group--Motor Parameters 2.....	104
6.17 PP Group--Motor Parameters 3.....	108
7. DESCRIPTION OF CHV190'S EXTENSION CARD	114
7.1 Description of I/O Extension Card	114
7.2 Description of Asynchronous PG Card	115
7.3 Description of Synchronous PG Card.....	119
7.4 Description of Modbus Communication Card.....	121
7.5 Description of Profibus Communication Card	123
7.6 Ethernet Communication Description	140
8. TROUBLE SHOOTING	141
8.1 Fault and Trouble Shooting.....	141
8.2 Common Faults and Solutions.....	146
9. MAINTENANCE	148
9.1 Daily Maintenance.....	148
9.2 Periodic Maintenance.....	149
9.3 Replacement of Wearing Parts.....	150
10. COMMUNICATION PROTOCOL	151
10.1 Interfaces	151
10.2 Communication Modes	151
10.3 Protocol Format.....	151
10.4 Protocol Function	152
10.5 Notice.....	157
10.6 CRC Check.....	157
10.7 Example.....	158
APPENDIX A APPLICATION MODE DESCRIPTION	164
A.0 Open loop sequence.....	164
A.1 Close loop sequence	165
APPENDIX B APPLICATION MODE DESCRIPTION	167
B.0 General Application Mode	167
B.1 Operating Lever Mode	167
B.2 Remote Control Mode.....	169

B.3 Hierarchical Operating Lever Mode	170
B.4 Hierarchical Remote Control Mode	171
B.5 Electric Potential Mode	173
B.6 Master-slave Power Equilibrium Host Mode	174
B.7 Master-slave Power Equilibrium Slave Mode	178
B.8 Master-slave Speed Synchronization Host Mode	179
B.9 Master-slave Speed Synchronization Slave Mode	182
APPENDIX C THE SELECTION GUIDE OF CHV190	184
C.1 Inverter Capacity Calculation	184
C.2 Renewable Energy Treatment	185
APPENDIX D RELATIVE DIMENSION OF INVERTER	189
D.1 External Dimension	189
D.2 Dimensions of External Keypad	190
D.3 Installation Space	191
D.4 Disassembly	192
APPENDIX E SPECIFICATIONS OF ACCESSORIES	193
E.1 Specifications of Breaker, Cable, Contactor and Reactor	193
APPENDIX F FUNCTION PARAMETERS	196

SAFETY PRECAUTIONS

Please read this operation manual carefully before installation, operation, maintenance or inspection.

In this manual, the safety precautions were sorted to "WARNING" or "CAUTION".



WARNING

Indicates a potentially hazardous situation which, if not, will result in death or serious injury.



CAUTION

Indicates a potentially hazardous situation which, if not avoided, will result in minor or moderate injury and physical damage. This sign is also used for alert of any un-safety operation.

In some cases, the contents of "CAUTION" could cause serious accident. Please follow these important precautions in any situation.

★ **NOTE** is the necessary step to ensure the proper operation.

WARNING

- **May cause injury or electric shock.**
- **Please follow the instructions in the manual before installation or operation.**
- **Disconnect all power line before opening front cover of unit. Wait at least 5 minute until DC Bus capacitors discharge.**
- **Use proper grounding techniques.**
- **Never connect AC power to output UVW terminals**

1. INTRODUCTION

1.1 Technology Features

• Input & output

- ◆ Input voltage range: $380 \pm 15\%$
- ◆ Input frequency range: 47~63Hz
- ◆ Output voltage range: 0~rated input voltage
- ◆ Output frequency range: 0~400Hz

• I/O features

- ◆ Programmable digital input: Provide 5 terminals which can accept ON-OFF input and 1 terminal can accept high speed pulse input (HDI1). 4 inputs can be extended by I/O extension card.
- ◆ Programmable analog input: AI1 can accept input of 0~10V, AI2 can accept input of 0~10V or 0~20mA.
- ◆ Programmable open collector output: Provide 2 output terminals, 1 output (open collector output or high speed pulse output) can be extended by I/O extension card.
- ◆ Relay output: Provide 2 output terminals. 1 output can be extended by I/O extension card.
- ◆ Analog output: Provide 1 output terminal, whose output scope can be 0~20 mA or 0~10 V, as chosen. 1 AO (0~20mA or 0~10V) can be extended by I/O card.
- ◆ Motor temperature detection: I/O extension card can provide 1 terminal for motor temperature detection which supports PT100/PT1000.

• Main control function

- ◆ Control mode: Sensorless vector control (SVC), vector control with PG (VC), V/F control.
- ◆ Overload capacity: 60s with 150% of rated current, 10s with 180% of rated current, 1s with 200% of rated current.
- ◆ Starting torque: 150% of rated torque at 0.5Hz (SVC); 200% of rated torque at 0 Hz (VC).
- ◆ Speed adjusting range: 1:100 (SVC); 1:1000 (VC)
- ◆ Speed accuracy: $\pm 0.5\%$ of maximum speed (SVC); $\pm 0.1\%$ of maximum speed (VC)
- ◆ Carrier frequency: 1.0 kHz~16.0 kHz.

• Functions

- ◆ Frequency reference source: Digital input, analog input, HDI Input, multi-speed

terminal, UP/DOWN terminal, Modbus communication, Profibus communication, master-slave mode given, classification multi-step speed given

- ◆ Run command source: Keypad, terminal, communication (support Modbus and Profibus communication command)
- ◆ Crane control logic: Brake, contactor control
- ◆ Starting pre-torque compensation
- ◆ DC braking at starting and stopping
- ◆ PG Card: Asynchronous PG Card (12V), synchronous PG Card (5V).
- ◆ Automatic voltage regulation (AVR): Automatically keep the output voltage stable when input voltage fluctuating
- ◆ Up to 30 fault protections: Protect from over current, over voltage, under voltage, over temperature, phase failure, over load etc.
- ◆ "Black box" function: 17 kinds of waveform can be saved at 0.2s before the last fault, which will make trouble shooting more convenient.

1.2 Description of Nameplate

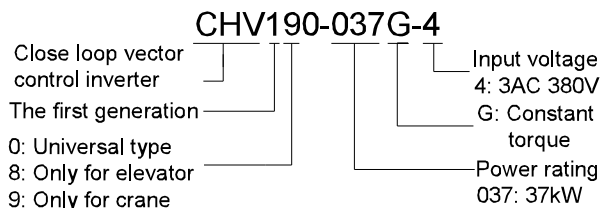
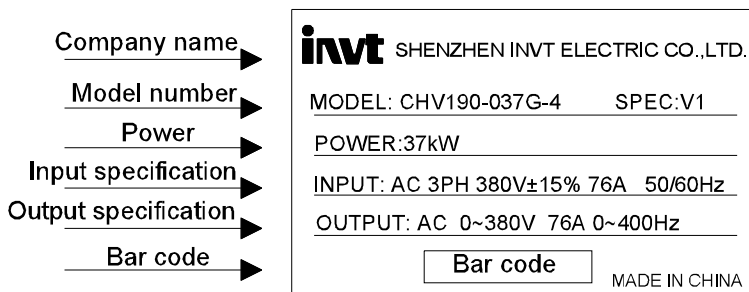

Figure 1.1 Nameplate of inverter

1.3 Selection Guide

Model No.	Rated power (kW)	Rated input current (A)	Rated output current (A)
3AC 380V±15%			
CHV190-018G-4	18.5	38	37
CHV190-022G-4	22.0	46.0	45.0
CHV190-030G-4	30.0	62.0	60.0
CHV190-037G-4	37.0	76.0	75.0
CHV190-045G-4	45.0	90.0	90.0
CHV190-055G-4	55.0	105.0	110.0
CHV190-075G-4	75.0	140.0	150.0
CHV190-090G-4	90.0	160.0	176.0
CHV190-110G-4	110.0	210.0	250.0
CHV190-132G-4	132.0	240.0	250.0
CHV190-160G-4	160.0	290.0	300.0
CHV190-185G-4	185.0	330.0	340.0
CHV190-200G-4	200.0	370.0	380.0
CHV190-220G-4	220.0	410.0	415.0
CHV190-250G-4	250.0	460.0	470.0
CHV190-280G-4	280.0	500.0	520.0
CHV190-315G-4	315.0	580.0	600.0
CHV190-350G-4	350.0	620.0	640.0
CHV190-400G-4	400.0	670.0	690.0
CHV190-500G-4	500.0	835.0	860.0

1.4 Parts Description

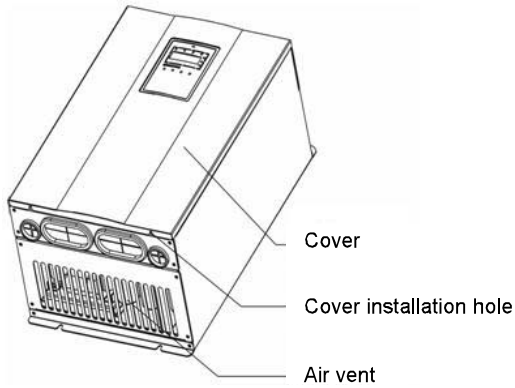
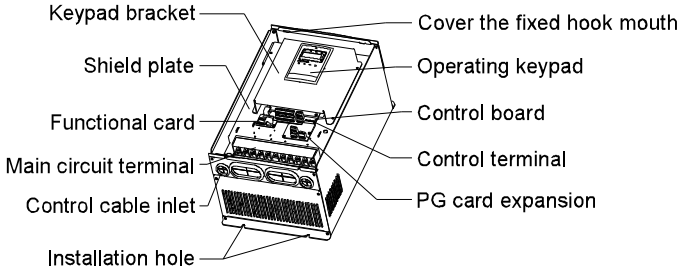

Figure 1.2 Part name of inverter

1.5 Description of Extension Card

Extension card	Description
Modbus communication card	Offer RS232 and RS485 dual physical communication interface 1. RS232 adopts standard DB9 master seat. 2. 3-hole RS485 interface, two communication modes can be switched by short-connecting module.
Profibus-DP communication card	Inverter can be connected to a Profibus-DP network; User can monitor and set parameters remotely in this way.
Asynchronous electromotor PG Card	Receive high-speed pulse from encoder to realize high-accuracy close-loop vector control. 1. Both push-and-pull input and open-circuit collector input. 2. Offer frequency division output, the frequency-division factor can be selected by dial switch, encode power is 12V.
Synchronization electromotor PG Card	Receive high-speed pulse from encoder to realize high-accuracy close-loop vector control. 1. SIN/COS encoder, UVW encoder, incremental encoder are compatible; 2. Offer frequency division output, the frequency-division factor can be selected by dial switch, encode power is 5V.
I/O extension card	Offer more input/output terminals to enhance the external function of inverter. RS485 and CAN terminals are valid. Notice: CAN communication interface can only be used by the master-slave control.

2. UNPACKING INSPECTION



CAUTION

- **Never install or operate any inverter that is damaged or missing components. Doing so can result in injury.**

Check the following items when unpacking the inverter,

1. Inspect the entire exterior of the Inverter to see if there are any scratches or other damage resulting from shipping.
2. Ensure there is operation manual and warranty card in the packing box.
3. Ensure the nameplate that it is you ordered.
4. Ensure the optional parts are what you need if you ordered any optional parts.

Please contact the local agent if there is any damage of inverter or optional parts.

3. DISASSEMBLE AND INSTALLATION



WARNING

- Any untrained person working on any parts/systems of inverter or any rule in the “Warning” being violated, that will cause severe injury or property damage. Only licensed person, who has been trained on design, installation, commissioning and operation of inverter, is permitted to operate this equipment.
- Input power cable must be connected tightly, and the equipment must be grounded securely.
- Even if the inverter is not in operating situation, the following terminals still have dangerous voltage:
 - Power Terminals: R, S, T;
 - Motor Connection Terminals: U, V, W.
- Can not install the inverter until discharged completely after the power supply is switched off for 5 minutes.
- The section area of grounding conductor must be no less than that of power supply cable.



CAUTION

- Lift the cabinet by its base; do not lift it by holding its panel. Otherwise the main unit will fall off to result in personal injury.
- Install the inverter on top of the fireproofing material (such as, metal) to prevent fire.
- When need install two or more inverters in one cabinet, cooling fan should be applied to make sure that the air temperature is lower than 45°C. Otherwise it could cause fire or damage the device.

3.1 Environmental Requirement

3.1.1 Temperature

Environment temperature range: -10°C ~ +40°C. Inverter will be derated if ambient temperature exceeds 40°C.

3.1.2 Humidity

Less than 95% RH, without dewfall.

3.1.3 Altitude

Inverter can output the rated power when installed with altitude of lower than 1000m. It will be derated when the altitude is higher than 1000m. For details, please refer to the following figure:

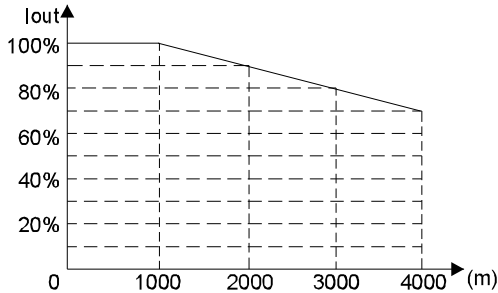

Figure 3.1 Relationship between output current and altitude

3.1.4 Impact and oscillation

It is not allowed that the inverter falls down or suffers from fierce impact or the inverter installed at the place that oscillation frequently. The maximum swing should less than 5.8m/s^2 (0.6g).

3.1.5 Electromagnetic radiation

Keep away from the electromagnetic radiation source.

3.1.6 Water

Do not install the inverter at the wringing or dewfall place.

3.1.7 Air pollution

Keep away from air pollution such as dusty, corrosive gas.

3.1.8 Storage

Do not store the inverter in the environment with direct sunlight, vapor, oil fog and vibration.

4. INSTALLATION AND COMMISSIONING

Start flowchart
 WARNING
<ul style="list-style-type: none"> • Startup process must be implemented by qualified electrical technicians. • Startup process must be strictly in accordance with the safety instructions. • Before startup, the situation of machine installation must be re-examined to make sure installation is good.
<ul style="list-style-type: none"> • Make sure that there will be no danger before starting. • The first start should be of no load because motor steering errors may result in drive equipment damage.
Start process
1. Power on
<ul style="list-style-type: none"> • Make sure that inverters are cut off less than 5 times within 10 minutes when they are power on, because repeatedly switching will lead to resistor overheating. • Make sure that keypad displays normal, DC-bus voltage displays proper and there is no fault warning.
2. Parameter setting
<ul style="list-style-type: none"> • Select motor control mode, P0.00 which is speed control mode selection is usually set to be 1 vector control with PG Card. • According to motor nameplate, set motor parameters P2.00~ P2.05, which are motor type, motor rated power, rated frequency, rated speed, rated voltage and rated current respectively. • Set the encoding parameters correctly according to the actual requirements. <ul style="list-style-type: none"> P4.00: encoder type P4.01: encoder pulses number P4.02: encoder direction. • Set autotuning acceleration and deceleration time parameter (P1.20, P1.21) according to load inertia to avoid over-voltage and over-current fault • Parameter autotuning, set the function code P0.07=1, press RUN to start rotation autotuning. The whole process need acceleration, deceleration time and additional time 60s.

3. Actual operating parameters adjustment

- Set a low frequency, if inverter displays PCE fault, please adjust P4.02 encoder direction.
- Adjust motor running direction according to actual demand, please adjust P0.05 running direction selection.
- Select inverter application mode according to actual requirements, please set P0.11 (Application mode choice).
- Adjust S curve of acceleration and deceleration, please set P1.11~P1.14.

4.1 Connections of Peripheral Devices

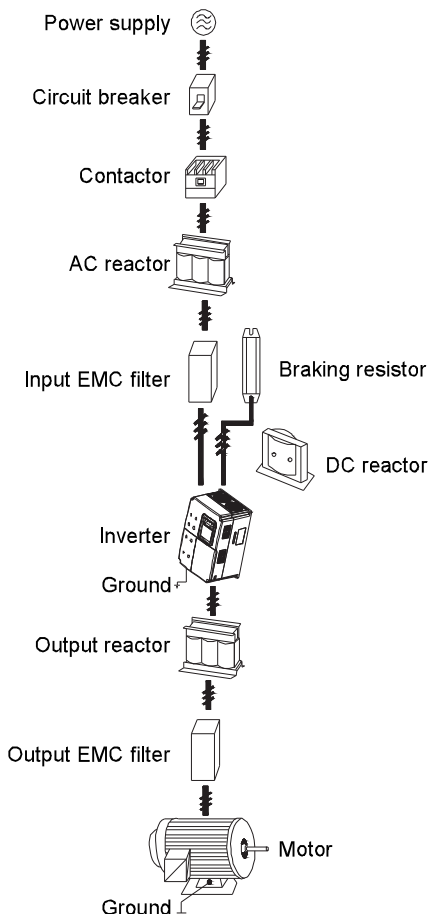

Figure 4.1 Connections of peripheral devices

4.2 Terminal configuration

4.2.1 Main circuit terminals

	(+) PB (-)	R	S	T	U	V	W	
		POWER			MOTOR			

Figure 4.2 Main circuit terminals (18.5~110kW).

R	S	T	U	V	W
POWER			MOTOR		
	P1	(+)	(-)		

Figure 4.3 Main circuit terminals (132~315kW).

R	S	T
U	V	W
PE	P1	(+)
		(-)

Figure 4.4 Main circuit terminals (350~500kW).

Main circuit terminal functions are summarized according to the terminal symbols in the following table. Wire the terminal correctly for the desired purposes.

Terminal	Description
R,S,T	Terminals of 3 phase AC input
(+),(-)	Spare terminals of external braking unit
P1,(+)	Spare terminals of external DC reactor
(-)	Terminal of negative DC bus
U,V,W	Terminals of 3 phase AC output
	Terminal of ground

4.2.2 Control Circuit Terminals

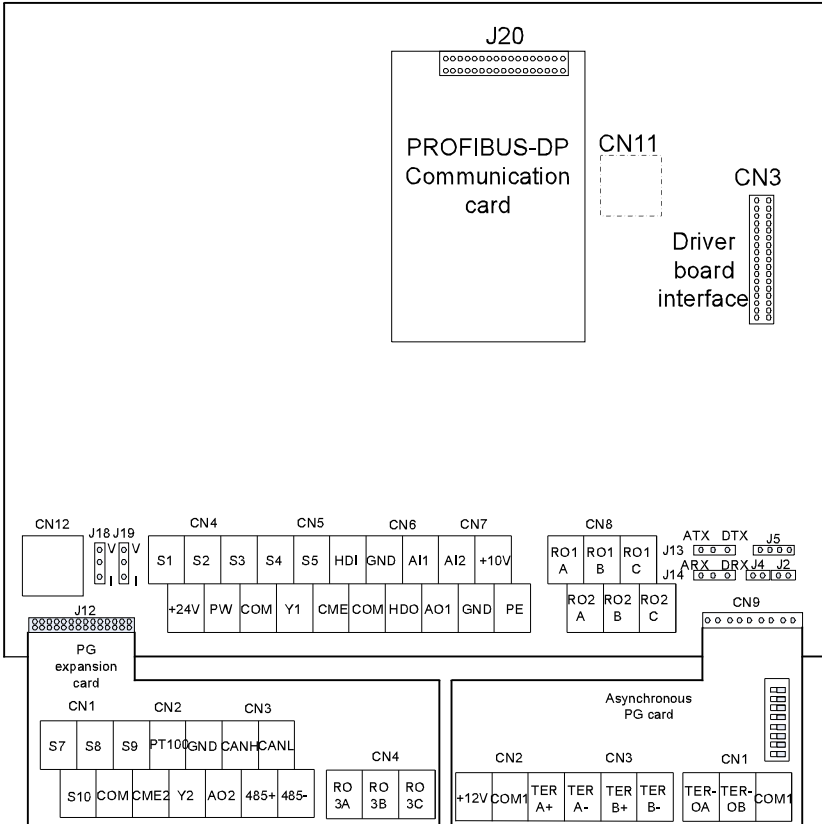

Figure 4.5 Interface distribution in the control board

Notice: CHV190 series inverter only supports one keypad whose interface is on the back of control board, and CN12 is for the Ethernet interface.

4.3 Typical Wiring Diagram

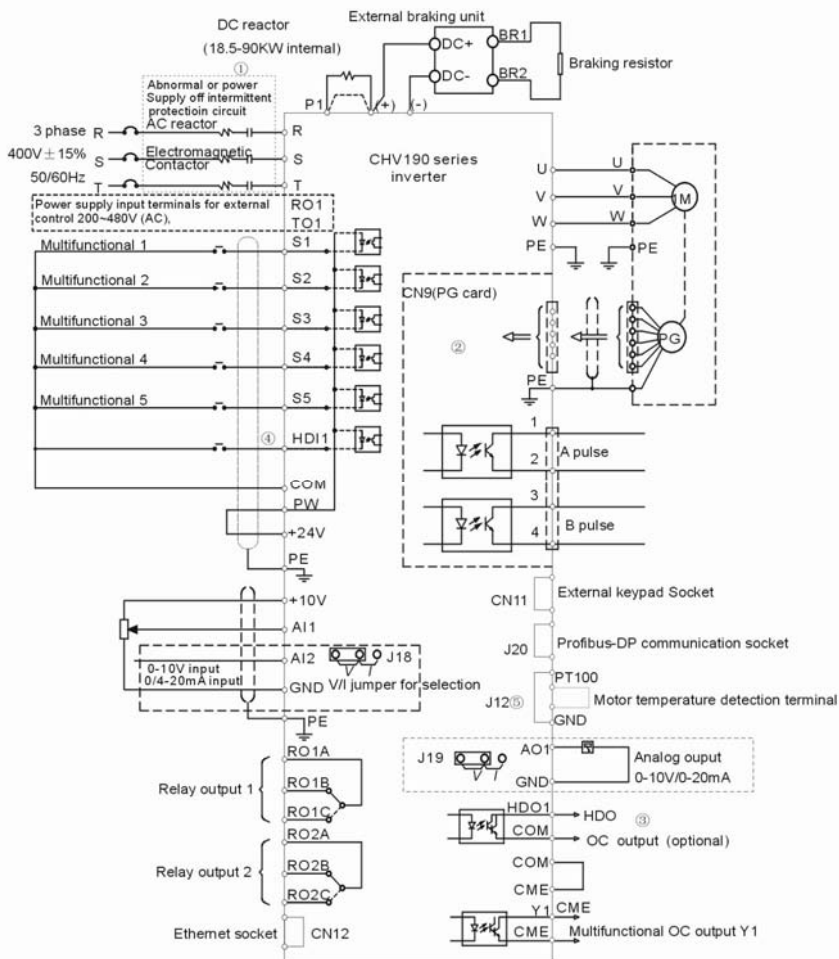

Figure 4. 6 Wiring diagram.

Notice:

1. Inverters between 18.5KW and 90KW have built-in DC reactor which is used to improve power factor. For inverters above 110KW, it is recommended to install DC reactor between P1 and (+).
2. For inverters above (including) 18.5KW, if need braking, should install external braking unit between (+) and (-).
3. +24V connect with PW as default setting. If user need external power supply,

disconnect +24V with PW and connect PW with external power supply.

4.4 Wiring the Main Circuits

4.4.1 Wiring at the side of power supply

- Circuit breaker

It is necessary to connect a circuit breaker which is compatible with the capacity of inverter between 3ph AC power supply and power input terminals (R, S, and T). The capacity of breaker is 1.5~2 times to the rated current of inverter. For details, see <Specifications of Breaker, Cable, and Contactor>.

- Contactor

In order to cut off the input power effectively when something is wrong in the system, contactor should be installed at the input side to control the ON-OFF of the main circuit power supply.

- AC reactor

In order to prevent the rectifier damage result from the large current, AC reactor should be installed at the input side. It can also prevent rectifier from sudden variation of power voltage or harmonic generated by phase-control load.

- Input EMC filter

The surrounding device may be disturbed by the cables when the inverter is working. EMC filter can minimize the interference. Just like the following figure.

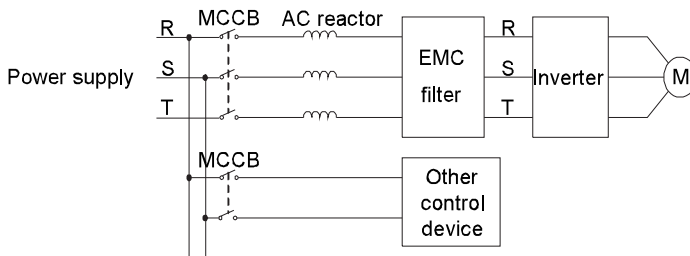

Figure 4.7 Wiring at input side.

4.4.2 Wiring for inverter

- DC reactor

DC reactor is built in CHV190 inverter from 18.5kW~90kW (380V classification) DC reactor can improve power factor, can avoid bridge rectifier damaged due to large-capacity transformer Ershi resulting in larger input current, can avoid rectifier circuit damage caused by sinusoidal.

- Braking unit and braking resistor

- Inverter of 18.5KW and above need connect external braking unit which should be installed at (+) and (-) terminals. The cable between inverter and braking unit should be less than 5m. The cable between braking unit and braking resistor should be less than 10m.
- The temperature of braking resistor will increase because the regenerative energy will be transformed to heat. Safety protection and good ventilation is recommended.

Notice: Be sure that the electric polarity of (+) (-) terminals is right; it is not allowed to connect (+) with (-) terminals directly, Otherwise damage or fire could occur.

4.4.3 Wiring at motor side of main circuit

• Output reactor

When the distance between inverter and motor is more than 50m, inverter may be tripped by over-current protection frequently because of the large leakage current resulted from the parasitic capacitance with ground. And the same time to avoid the damage of motor insulation, the output reactor should be installed.

• Output EMC filter

EMC filter should be installed to minimize the leakage current caused by the cable and minimize the radio noise caused by the cables between the inverter and cable. Just see the following figure.

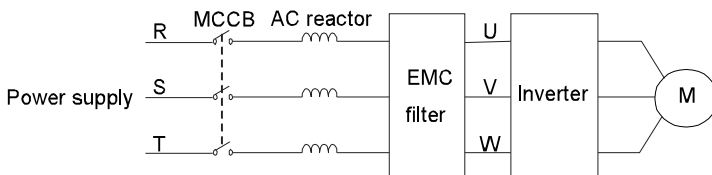

Figure 4.8 Wiring at motor side.

4.4.4 Wiring of regenerative unit

Regenerative unit is used for putting the electricity generated by braking of motor to the grid. Compared with traditional 3 phase inverse parallel bridge type rectifier unit, regenerative unit uses IGBT so that the total harmonic distortion (THD) is less than 4%. Regenerative unit is widely used for centrifugal and hoisting equipment.

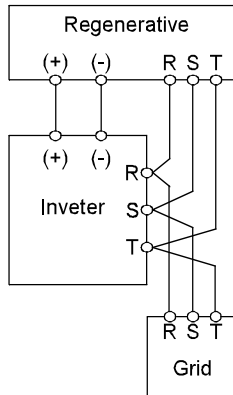

Figure 4.9 Wiring of regenerative unit.

4.4.5 Ground Wiring (PE)

In order to ensure safety and prevent electrical shock and fire, terminal PE must be grounded with ground resistance. The ground wire should be big and short, and it is better to use copper wire ($>3.5\text{mm}^2$). When multiple inverters need to be grounded, do not loop the ground wire.

4.5 Wiring Control Circuit Terminals

4.5.1 Precautions

- Use shielded or twisted-pair cables to connect control terminals.
- Connect the ground terminal (PE) with shield wire.
- The cable connected to the control terminal should leave away from the main circuit and heavy current circuits (including power supply cable, motor cable, relay and contactor connecting cable) at least 20cm and parallel wiring should be avoided. It is suggested to apply perpendicular wiring to prevent inverter malfunction caused by external interference.

4.5.2 Control circuit terminals

Terminal	Description
S1~S5(S7~S10)	ON-OFF signal input, optical coupling with PW and COM. Input voltage range: 9~30V Input impedance: 3.3kΩ
HDI1	High speed pulse or ON-OFF signal input, optical coupling with PW and COM. Pulse input frequency range: 0~50kHz Input voltage range: 9~30V Input impedance: 1.1kΩ

Terminal	Description
PW	External power supply. +24V terminal is connected to PW terminal as default setting. If user need external power supply, disconnect +24V terminal with PW terminal and connect PW terminal with external power supply.
+24V	Provide output power supply of +24V. Maximum output current: 150mA
AI1	Analog input, 0~10V Input impedance: 10kΩ
AI2	Analog input, 0~10V/ 0~20mA, switched by J18. Input impedance: 10kΩ (voltage input) / 250Ω (current input)
GND	Common ground terminal of analog signal and +10V. GND must isolated from COM.
Y1(Y2)	Open collector output terminal, the corresponding common ground terminal is CME. External voltage range: 0~24V Output current range: 0~50mA
CME	Common terminal of open collector output
COM	Common ground terminal for digital signal and +24V (or external power supply).
+10V	Supply +10V for inverter.
HDO	High speed pulse output terminal. The corresponding common ground terminal is COM. Output frequency range: 0~50 kHz
AO1(AO2)	Provide voltage or current output which can be switched by J19. Output range: 0~10V/ 0~20mA
PE	Ground terminal.
RO1A,RO1B,RO1C	RO1 relay output: RO1A common; RO1B NC; RO1C NO. Contact capacity: AC 250V/3A, DC 30V/1A.
RO2A,RO2B,RO2C	RO2 relay output: RO2A common; RO2B NC; RO2C NO. Contact capacity: AC 250V/3A, DC 30V/1A.
RO3A,RO3B,RO3C	RO3 relay output: RO3A common; RO3B NC; RO3C NO. Contact capacity: AC 250V/3A, DC 30V/1A.

4.5.3 Jumper on control board

Terminal	Description
J2, J4, J5	It is prohibited to be connected together, otherwise it will cause inverter malfunction.
J13, J14	Do not change factory default connection of J13 (marked with ATX) and J14 (marked with ARX), otherwise it will cause communication malfunction.
J18	Switch between (0~10V) voltage input and (0~20mA) current input. V connect to GND means voltage input; I connect to GND means current input.
J19	Switch between (0~10V) voltage output and (0~20mA) current output. V connect to OUT means voltage output; I connect to OUT means current output.

4.6 Installation Guideline to EMC Compliance

4.6.1 General knowledge of EMC

EMC is the abbreviation of electromagnetic compatibility, which means the device or system has the ability to work normally in the electromagnetic environment and will not generate any electromagnetic interference to other equipments.

EMC includes two subjects: electromagnetic interference and electromagnetic anti-jamming.

According to the transmission mode, Electromagnetic interference can be divided into two categories: conducted interference and radiated interference.

Conducted interference is the interference transmitted by conductor. Therefore, any conductors (such as wire, transmission line, inductor, capacitor and so on) are the transmission channels of the interference.

Radiated interference is the interference transmitted in electromagnetic wave, and the energy is inverse proportional to the square of distance.

Three necessary conditions or essentials of electromagnetic interference are: interference source, transmission channel and sensitive receiver. For customers, the solution of EMC problem is mainly in transmission channel because of the device attribute of disturbance source and receiver can not be changed.

4.6.2 EMC features of inverter

Like other electric or electronic devices, inverter is not only an electromagnetic

interference source but also an electromagnetic receiver. The operating principle of inverter determines that it can produce certain electromagnetic interference noise. And the same time inverter should be designed with certain anti-jamming ability to ensure the smooth working in certain electromagnetic environment. The following is its EMC features:

- Input current is non-sine wave. The input current includes large amount of high-harmonic waves that can cause electromagnetic interference, decrease the grid power factor and increase the line loss.
- Output voltage is high frequency PWM wave, which can increase the temperature rise and shorten the life of motor. And the leakage current will also increase, which can lead to the leakage protection device malfunction and generate strong electromagnetic interference to influence the reliability of other electric devices.
- As the electromagnetic receiver, too strong interference will damage the inverter and influence the normal using of customers.
- In the system, EMS and EMI of inverter coexist. Decrease the EMI of inverter can increase its EMS ability.

4.6.3 EMC Installation Guideline

In order to ensure all electric devices in the same system to work smoothly, this section, based on EMC features of inverter, introduces EMC installation process in several aspects of application (noise control, site wiring, grounding, leakage current and power supply filter). The good effective of EMC will depend on the good effective of all of these five aspects.

4.6.3.1 Noise control

All the connections to the control terminals must use shielded wire. And the shield layer of the wire must ground near the wire entrance of inverter. The ground mode is 360 degree annular connection formed by cable clips. It is strictly prohibitive to connect the twisted shielding layer to the ground of inverter, which greatly decreases or loses the shielding effect.

Connect inverter and motor with the shielded wire or the separated cable tray. One side of shield layer of shielded wire or metal cover of separated cable tray should connect to ground, and the other side should connect to the motor cover. Installing an EMC filter can reduce the electromagnetic noise greatly.

4.6.3.2 Site wiring

Power supply wiring: the power should be separated supplied from electrical transformer. Normally it is 5 core wires, three of which are fire wires, one of which is the neutral wire, and one of which is the ground wire. It is strictly prohibitive to use the same line to be both

the neutral wire and the ground wire

Device categorization: there are different electric devices contained in one control cabinet, such as inverter, filter, PLC and instrument etc, which have different ability of emitting and withstanding electromagnetic noise. Therefore, it needs to categorize these devices into strong noise device and noise sensitive device. The same kinds of device should be placed in the same area, and the distance between devices of different category should be more than 20cm.

Wire Arrangement inside the control cabinet: there are signal wire (light current) and power cable (strong current) in one cabinet. For the inverter, the power cables are categorized into input cable and output cable. Signal wires can be easily disturbed by power cables to make the equipment malfunction. Therefore when wiring, signal cables and power cables should be arranged in different area. It is strictly prohibitive to arrange them in parallel or interlacement at a close distance (less than 20cm) or tie them together. If the signal wires have to cross the power cables, they should be arranged in 90 angles. Power input and output cables should not either be arranged in interlacement or tied together, especially when installed the EMC filter. Otherwise the distributed capacitances of its input and output power cable can be coupling each other to make the EMC filter out of function.

4.6.3.3 Ground

Inverter must be ground safely when in operation. Grounding enjoys priority in all EMC methods because it does not only ensure the safety of equipment and persons, but also is the simplest, most effective and lowest cost solution for EMC problems.

Grounding has three categories: special pole grounding, common pole grounding and series-wound grounding. Different control system should use special pole grounding, and different devices in the same control system should use common pole grounding, and different devices connected by same power cable should use series-wound grounding.

4.6.3.2 Leakage current

Leakage current includes line-to-line leakage current and over-ground leakage current. Its value depends on distributed capacitances and carrier frequency of inverter. The over-ground leakage current, which is the current passing through the common ground wire, can not only flow into inverter system but also other devices. It also can make leakage current circuit breaker, relay or other devices malfunction. The value of line-to-line leakage current, which means the leakage current passing through distributed capacitors of input output wire, depends on the carrier frequency of inverter, the length and section areas of motor cables. The higher carrier frequency of inverter, the longer of the motor

cable and/or the bigger cable section area, the larger leakage current will occur.

Countermeasure:

Decreasing the carrier frequency can effectively decrease the leakage current. In the case of motor cable is relatively long (longer than 50m), it is necessary to install AC reactor or sinusoidal wave filter at the output side, and when it is even longer, it is necessary to install one reactor at every certain distance.

4.6.3.5 EMC Filter

EMC filter has a great effect of electromagnetic decoupling, so it is preferred for customer to install it.

For inverter, noise filter has following categories:

- Noise filter installed at the input side of inverter;
- Install noise isolation for other equipment by means of isolation transformer or power filter.

4.6.4 If user install inverter and EMI filter according to the installation guideline, we believe inverter system comply with following compliance.

- EN61000-6-4
- EN61000-6-3
- EN61800-3

4.6.5 Notice

- **This type of PDS is not intended to be used on a low-voltage public network which supplies domestic premise;**
- **Radio frequency interference is expected if used on such a network.**

5. OPERATION

5.1 Operating Keypad Description

5.1.1 Keypad schematic diagram

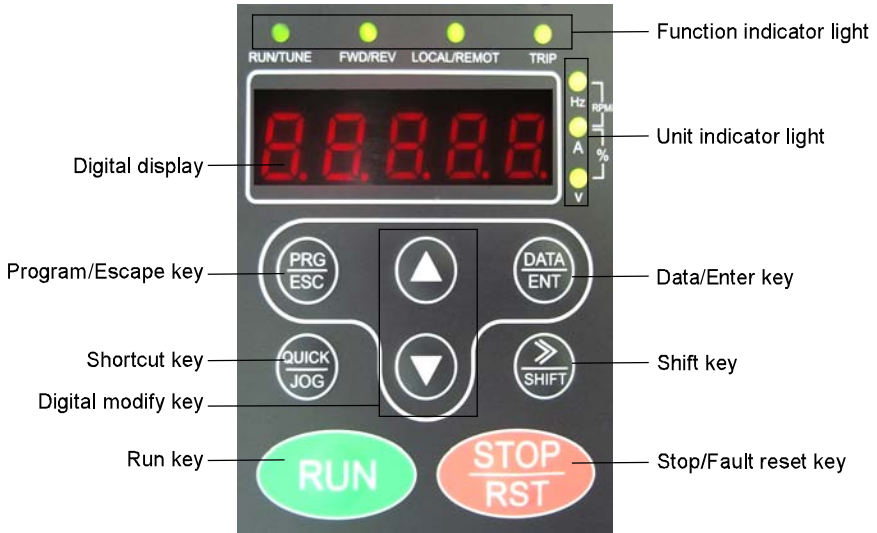





Figure 5.1 Keypad schematic diagrams.

5.1.2 Button function description

Button	Name	Description
	Programming Key	Entry or escape of first-level menu.
	Enter Key	Progressively enter menu and confirm parameters.
	UP Increment Key	Progressively increase data or function codes.
	DOWN Decrement Key	Progressive decrease data or function codes.
	Shift Key	In parameter setting mode, press this button to select the bit to be modified. In other modes, cyclically displays parameters by right shift

Button	Name	Description
	Run Key	Start to run the inverter in keypad control mode.
	STOP/RST Key	In running status, restricted by P7.04, can be used to stop the inverter. When fault alarm, can be used to reset the inverter without any restriction.
	Shortcut Key	Determined by Function Code P7.03: 0: Jog operation 1: Switch between forward and reverse 2: Clear the UP/DOWN settings. 3: Quick debugging mode1 (by menu) 4: Quick debugging mode2 (by latest order) 5: Quick debugging mode3 (by non-factory setting parameters)
	Combination Key	Pressing the RUN and STOP/RST at the same time can achieve inverter coast to stop.

5.1.3 Indicator light description

5.1.3.1 Function indicator light description

Function indicator	Description
RUN/TUNE	Extinguished: stop status Flickering: parameter autotuning status Light on: operating status
FWD/REV	Extinguished: forward operation Light on: reverse operation.
LOCAL/REMOT	Extinguished: keypad control Flickering: terminal control Light on: communication control
TRIP	Extinguished: normal operation status Flickering: overload pre-warning status

5.1.3.2 Unit indicator light description

Function indicator	Description
Hz	Frequency unit
A	Current unit
V	Voltage unit
RPM	Rotating speed unit
%	Percentage

5.1.3.3 Digital display

Have 5 digit LED , which can display all kinds of monitoring data and alarm codes such as reference frequency, output frequency and so on.

5.2 Operation Process

5.2.1 Parameter setting

Three levels of menu are:

- Function code group (first-level);
- Function code (second-level);
- Function code value (third-level).

Remarks:

Press both the PRG/ESC and the DATA/ENT can return to the second-class menu from the third-class menu. The difference is: pressing DATA/ENT will save the set parameters into the control panel, and then return to the second-class menu with shifting to the next function code automatically; while pressing PRG/ESC will directly return to the second-class menu without saving the parameters, and keep staying at the current function code.

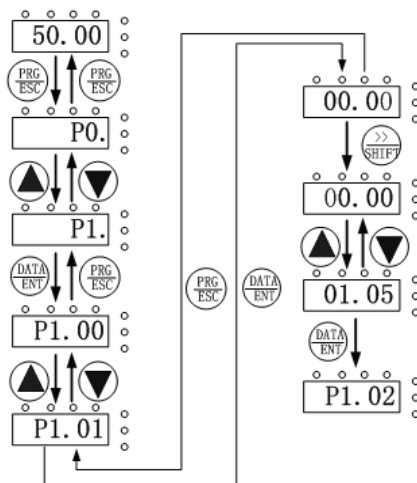

Figure 5.2 Flow chart of parameter setting.

Under the third-class menu, if the parameter has no flickering bit, it means the function code cannot be modified. The possible reasons could be:

- This function code is not modifiable parameter, such as actual detected parameter, operation records and so on;
- This function code is not modifiable in running status, but modifiable in stop status.

5.2.2 Fault reset

If the inverter has fault, it will prompt the related fault information. User can use **STOP/RST** or according terminals determined by P5 Group to reset the fault. After fault reset, the inverter is at stand-by state. If user does not reset the inverter when it is at fault state, the inverter will be at operation protection state, and can not run.

5.2.3 Parameter copy

For details, please refer to the instructions of LCD keyboard functions

5.2.4 Motor parameter autotune

If “Sensorless Vector Control” or “Vector Control with PG” mode is chosen, motor nameplate parameters must be input correctly as the autotuning is based on it. The performance of vector control depends on the parameters of motor strongly, so to achieve excellent performance, firstly must obtain the parameter of motor exactly.

The procedure of motor parameter autotuning is as follows:

Firstly, choose keypad command as the run command source (P0.01).

And then input following parameters according to the actual motor parameters:

P2.00: motor type selection

P2.01: motor rated power

P2.02: motor rated frequency;

P2.03: motor rated speed;

P2.04: motor rated voltage;

P2.05: motor rated current

Encoder parameters determination:

P4.00: encoder type selection;

P4.01: encoder pulses number

Set P0.07 to be 1, and for the detail process of motor parameter autotuning, please refer to the description of Function Code P0.07. And then press **RUN** on the keypad panel, the inverter will automatically calculate following parameter of the motor:

P2.07: motor stator resistance;

P2.08: motor rotor resistance;

P2.09: motor stator and rotor inductance;

P2.10: motor stator and rotor mutual inductance;

P2.11: motor current without load; motor autotuning is finished.

In the self-learning process, the keyboard will show TUN-1, TUN-2. When the keyboard displays END, the motor autotuning is finished. Using **>> / SHIFT** can change parameters and monitor running state of inverter.

Notice: The motor should be uncoupled with its load; otherwise, the motor parameters obtained by autotuning may be incorrect.

5.2.5 Password Settings:

CHV190 series inverter provides user password protection function. When P7.00 is zero, which is user's password, quitting code editing state can make password protection effective, then pressing **PRG/ESC** can enter code editing state, "-----" will be showed. Operator must enter a correct.

To cancel password protection function, setting P7.00 to be zero is ok. User's password has no protection to the parameter on shortcut menu.

5.3 Running State

5.3.1 Power-on initialization

Firstly the system initializes during the inverter power-on, and LED displays "8888". After the initialization is completed, the inverter is on stand-by status.

5.3.2 Stand-by

At stop or running status, parameters of multi-status can be displayed. Whether or not to display this parameter can be chosen through Function Code P7.06 (Running status display selection) and P7.07 (Stop status display selection) according to binary bits, the detailed description of each bit please refer to the function code description of P7.06 and P7.07.

In stop status, there are sixteen parameters which can be chosen to display or not. They are: reference frequency, fault code, DC bus voltage, input terminal status, output terminal status, motor pole pairs, analog AI1, analog AI2, HDI1 frequency, and some reserved parameters. Whether or not to display can be determined by setting the corresponding binary bit of P7.07. Press the **>>/SHIFT** to scroll through the parameters in right order.

5.3.3 Operation

In running status, there are sixteen running parameters which can be chosen to display or not. They are: running frequency, reference frequency, DC bus voltage, output voltage, output current, rotating speed, output power, output torque, input terminal status, output terminal status, analog AI1, analog AI2, HDI1 frequency, magnetic pole position, torque Compensation and some reserved parameters. Whether or not to display can be determined by setting the corresponding binary bit of P7.06. Press the **>>/SHIFT** to scroll through the parameters in right order .

5.3.4 Fault

In fault status, inverter will display parameters of STOP status besides parameters of fault status. Press the **>>/SHIFT** to scroll through the parameters in right order.

6. DETAILED FUNCTION DESCRIPTION

6.1 P0 Group--Basic Function

Function Code	Name	Description	Setting Range	Factory Setting
P0.00	Speed control mode	0:Sensorless vector control 1:Vector control With PG 2:V/F control	0~2	1

0: Sensorless vector control: sensorless vector control is only suitable for motor commissioning or some application need not high accuracy.

1: Vector control with PG: The closed-loop vector is used for high accuracy speed control and quick dynamic response working with encoder,

2: V/F control: It is only suitable for motor commissioning or some application need not high accuracy.

Notice:

Select vector control mode, you must correctly set the motor nameplate parameters and encoding parameters, and in order to obtain accurate motor parameters self-learning should be finished before running. Only with accurate motor parameters can play a high-performance vector control.

Adjust the parameters of vector control (P3 group) can be optimized vector control performance.

Function Code	Name	Description	Setting Range	Factory Setting
P0.01	Run command source	0: Keypad (LED extinguished) 1: Terminal (LED flickering) 2: Communication (LED lights on) 3: Profibus communication (LED lights on)	0~3	1

The control commands of inverter include: start, stop, forward run, reverse run, jog, fault reset and so on.

0: Keypad (LED extinguished);

Both **RUN** and **STOP/RST** key are used for running command control. If Multifunction key **QUICK/JOG** is set as FWD/REV switching function (P7.03 is set to be 1), it will be used to change the rotating orientation. In running status, pressing **RUN** and **STOP/RST** in the same time will cause the inverter coast to stop.

1: Terminal (LED flickering)

The operation, including forward run, reverse run, forward jog, reverse jog etc. can be controlled by multifunctional input terminals.

2: Modbus Communication (LED lights on)

Command from the host computer through Modbus communication control. Using this must select Modbus serial communication interface expansion cards which are matched to CHV190.

3: Profibus communication (LED lights on)

Command from the host computer through Profibus communication control. Using this must select Profibus communication interface of the expansion cards.

Function Code	Name	Description	Setting Range	Factory Setting
P0.02	Speed instruction selection	0: Keypad: 1: AI1 2: AI2 3: HDI1 4: Multi-steps speed 5: UP/DOWN terminal 6: Modbus Communication 7: Profibus communication 8: Hierarchical multi-stage speed	0~8	0

0: Keypad: Please refer to description of P0.04

1: AI1

2: AI2

The reference speed is set by analog input. AI1 is 0~10V voltage input terminal, while AI3 is -10V~10V voltage input.

Notice:

- **For detailed relationship between analog input voltage and frequency, please refer to description of P5.15~P5.19.**
- **100% of AI is corresponding to maximum frequency.**

3: HDI1

The reference speed is set by high speed pulse input.

Pulse specification: pulse voltage range 9~30V, and the frequency range 0.0~50.0 kHz.

Pulse input setting 100.0% corresponds to the maximum positive frequency (P0.03); s
-100.0% corresponds to the maximum frequency of the reverse.

4: Multi-steps speed

Select this mode, converter runs with multi-step speed. Running speed is determined by P1 and P5. If P0.02 is not set as multi-step speed, then the multi-step speed settings have priority.

Up to 8 multi-step speed given is set though binary mode, Please refer to P1.

5: UP/DOWN terminal

Modified by an external terminal for frequency reference, frequency increment and decrement.

Notice: The frequency cleared automatically when shutdown.

6: Modbus Communication

Frequency command is given from the host computer via Modbus communication. For details, see Chapter 10 "communication protocol."

7: Profibus communication

Speed instruction is given by the Profibus communication. For details, see the Profibus communication protocol.

8: Hierarchical multi-step speed

supports up to six steps speed under hierarchical multi-step speed mode, running speed is determined by the P1 and P5 group. Please refer to P1 in order to know combination relationship.

Function Code	Name	Description	Setting Range	Factory Setting
P0.03	Maximum frequency	10.0Hz ~400.00Hz	10.0~400.00	50.00Hz

P0.03 is the maximum frequency which inverter can output, this value is set according to the actual situation. The frequency is the basis for converter to be fast or slow.

Function Code	Name	Description	Setting Range	Factory Setting
P0.04	Keypad reference frequency	0.00~P0.03	0.00~P0.03	50.00Hz

When P0.03 is set to be 0, this parameter is the initial value of inverter reference

frequency.

Function Code	Name	Description	Setting Range	Factory Setting
P0.05	Running direction selection	0: Forward 1: Reverse 2: Forbid reverse	0~2	0

Notice:

- The rotation direction of motor is corresponding to the wiring of motor.
- When the factory setting is restored (P0.12 is set to be 1), the rotation direction of motor may be changed. Please be cautious to use.
- If P0.05 is set to 2, user can not change rotation direction of motor by

QUICK/JOG or terminal.

Function Code	Name	Description	Setting Range	Factory Setting
P0.06	Carrier frequency	1.0~16.0kHz	1.0~16.0	Depend on model

Carrier frequency	Electromagnetic noise	Noise leakage current	Radiating
1 kHz	↑ Big	↑ Small	↑ Small
10 kHz			
16 kHz	↓ Small	↓ Big	↓ Big

Figure 6.1 Effect of carrier frequency

Model	Carrier frequency	Factory Setting(kHz)
G Model: 18.5kW~55kW		4
G Model: 75kW~185kW		2
G Model: >185kw		1

Carrier frequency will affect the noise of motor and the EMI of inverter.

If the carrier frequency is increased, it will cause better current wave, less harmonic current and lower noise of motor.

Notice:

- The factory setting is optimal in most cases. Modification of this parameter is not recommended.

- If the carrier frequency exceeds the factory setting, the inverter must be derated because the higher carrier frequency will cause more switching loss, higher temperature rise of inverter and stronger electromagnetic interference.
- If the carrier frequency is lower than the factory setting, it is possible to cause less output torque of motor and more harmonic current.

Function Code	Name	Description	Setting Range	Factory Setting
P0.07	Motor parameters autotuning	0: No action 1: Rotation autotuning 2: Static autotuning	0~2	0

0: No action: Forbidding autotuning.

1: Rotation autotuning:

- Do not connect any load to the motor when performing autotuning and ensure the motor is in static status. Otherwise the parameters detected by autotuning will be incorrect; it may influence the performance of inverter. Specific self-learning process, taking into account the following flowchart.
- Set the proper acceleration and deceleration speed (P1.20 and P1.21) according to the motor inertia before performing autotuning. Otherwise it may cause over-current and over-voltage fault during autotuning.

In the process of parameter self-learning, pressing **>>/SHIFT** can switch keyboard display parameters, monitor inverter run state; pressing **STOP/RST** can terminate self-learning process at any time.

CHV190 series special inverter for crane

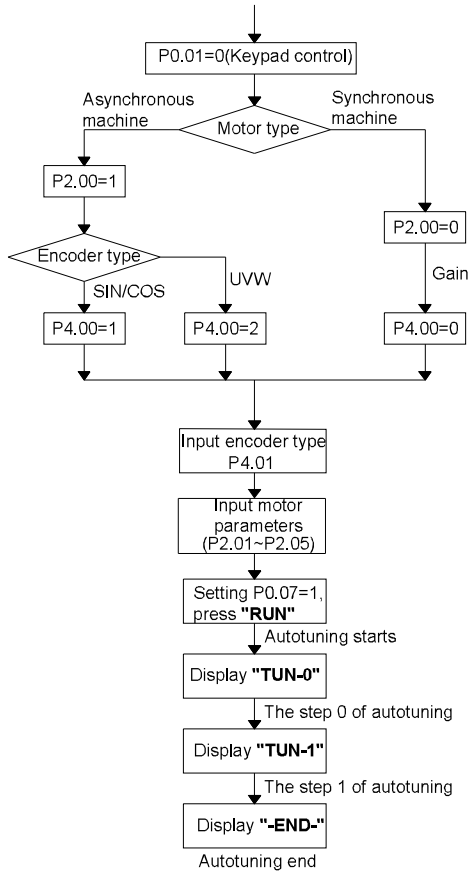

Figure 6.2 Flow chart for motor 1 autotuning

If you choose motor 2 at this time, then the current autotuning of the motor is 2#, for details please refer to the flow chart of motor 1

2: Static autotuning:

- If it is difficult to disconnect the load, static autotuning is recommended.
- The operation process is the same as rotation autotuning except step c.

Notice: The Mutual inductance and current without load will not be detected by static autotuning, if needed user should input suitable value according to experience.

Function Code	Name	Description	Setting Range	Factory Setting
P0.08~P0.10	Reserved	0~65535	0~65535	0

Function Code	Name	Description	Setting Range	Factory Setting
P0.11	Application mode selection	0: Common application mode 1: Operating lever mode 2: Remote Mode 3: Hierarchical operating lever mode 4: Hierarchical remote mode 5: Electric potentiometer mode 6: Master-slave power equilibrium host mode 7: Master-slave power equilibrium subordinate mode 8: Master-slave speed synchronization host mode 9: Master-slave speed synchronization subordinate mode	0~9	0

The users make selection based on the actual application, please refer to appendix part to know corresponding model, when only need setting this one parameter to achieve the basic application requirements.

Function Code	Name	Description	Setting Range	Factory Setting
P0.12	Restore parameters	0: No action 1: Restore factory setting 2: Clear fault records	0~2	0

Notice: This function code will restore to 0 automatically when complete the function operation.

6.2 P1 Group--Speed Curve

Function Code	Name	Description	Setting Range	Factory Setting
P1.00	Multi-step speed 0	-100.0~100.0%	-100.0~100.0	0.0%
P1.01	Multi-step speed 1	-100.0~100.0%	-100.0~100.0	0.0%
P1.02	Multi-step speed 2	-100.0~100.0%	-100.0~100.0	0.0%
P1.03	Multi-step speed 3	-100.0~100.0%	-100.0~100.0	0.0%
P1.04	Multi-step speed 4	-100.0~100.0%	-100.0~100.0	0.0%
P1.05	Multi-step speed 5	-100.0~100.0%	-100.0~100.0	0.0%
P1.06	Multi-step speed 6	-100.0~100.0%	-100.0~100.0	0.0%
P1.07	Multi-step speed 7	-100.0~100.0%	-100.0~100.0	0.0%

P1.00~P1.07 defines a multi-stage classification for a given speed; there are two combinations for the speed:

1. Binary multi-step speed terminal (P0.02 = 4): eight steps speed choices (P1.00 ~ P1.07) can be achieved through the combination of three-speed terminals (MS1, MS2, MS3).
2. Hierarchical multi-step speed (P0.02 = 8): up to six level speed options (P1.00 ~ P1.05) can be achieved through the combination of five multi-step speed.

In normal mode, multi-speed function is valid, and its corresponding binary combinations are as follows:

Multi-step speed terminal MS1	Multi-step speed terminal MS2	Multi-step speed terminal MS3	Speed setting	Function code
OFF	OFF	OFF	Multi-step speed 0	P1.00
ON	OFF	OFF	Multi-step speed 1	P1.01
OFF	ON	OFF	Multi-step speed 2	P1.02
ON	ON	OFF	Multi-step speed 3	P1.03
OFF	OFF	ON	Multi-step speed 4	P1.04
ON	OFF	ON	Multi-step speed 5	P1.05

Multi-step speed terminal MS1	Multi-step speed terminal MS2	Multi-step speed terminal MS3	Speed setting	Function code
OFF	ON	ON	Multi-step speed 6	P1.06
ON	ON	ON	Multi-step speed 7	P1.07

In the other mode (crane mode), grading given is valid and its compositions are as follows:

Hierarchical given terminal 1	Hierarchical given terminal 2	Hierarchical given terminal 3	Hierarchical given terminal 4	Hierarchical given terminal 5	Speed setting	Function Code
OFF	OFF	OFF	OFF	OFF	Hierarchical given 0	P1.00
ON	OFF	OFF	OFF	OFF	Hierarchical given 1	P1.01
ON	ON	OFF	OFF	OFF	Hierarchical given 2	P1.02
ON	ON	ON	OFF	OFF	Hierarchical given 3	P1.03
ON	ON	ON	ON	OFF	Hierarchical given 4	P1.04
ON	ON	ON	ON	ON	Hierarchical given 5	P1.05

Notice: Only the low-level Hierarchical given is ON, the up-level Hierarchical given will be ready for switching to ON.

Function Code	Name	Description	Setting Range	Factory Setting
P1.08	Acceleration /Deceleration mode	0:Linear 1:S curve	0~1	1
P1.09	Linear acceleration time	0.0~3600.0s	0.0~3600.0	20.0s
P1.10	Linear deceleration time	0.0~3600.0s	0.0~3600.0	20.0s

Function Code	Name	Description	Setting Range	Factory Setting
P1.11	Start section of acceleration S curve	0.1~50.0%	0.1~50.0	10.0%
P1.12	End section of acceleration S curve	0.1~50.0%	0.1~50.0	10.0%
P1.13	Start section of deceleration S curve	0.1~50.0%	0.1~50.0	10.0%
P1.14	End section of deceleration S curve	0.1~50.0%	0.1~50.0	10.0%
P1.15	Start frequency	0.00~10.00Hz	0.00~10.00	0.00Hz
P1.16	Starting frequency keeping time	0.00~5.00s	0.00~5.00	0.00s

P1.11 and P1.12 are only active when P1.08=1. During t_1 period, the change rate of output frequency increases from 0; During t_2 period, the change rate of output frequency decrease to 0; During the period between t_1 and t_2 , the change rate of output frequency remain constant.

The curvature of S curve is codetermined by ACC/DEC time, start section time and end section time.

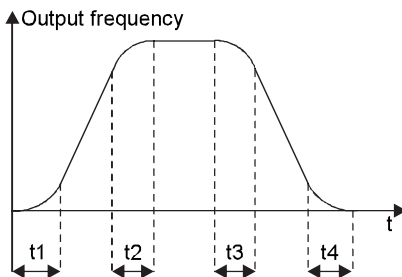

Figure 6.3 S curve diagram.

P1.15 (start frequency) is the initial velocity when inverter starts. If the setting speed is less than starting speed, the inverter output frequency is 0; only when setting speed is greater than or equal to the starting speed, the inverter can run according to s curve. Set

appropriate starting speed to overcome the static friction when the crane starts to reduce impact.

P1.16 (starting speed keeping time) is the time that inverter starts with the start running speed.

Function Code	Name	Description	Setting Range	Factory Setting
P1.17	Jog reference	0.00~P0.03	0.00~P0.03	5.00Hz
P1.18	Jog acceleration time	0.0~3600.0s	0.0~3600.0	20.0s
P1.19	Jog deceleration time	0.0~3600.0s	0.0~3600.0	20.0s

Set jog speed, jog acceleration/deceleration speed follow the jog curve as follows.

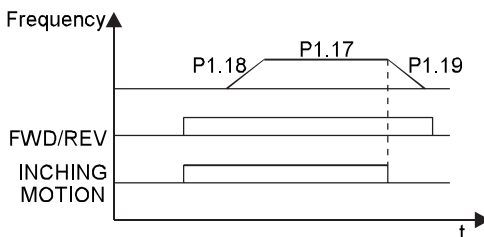

Figure 6.4 Jog running curve

Notice: The speed selection priority is as follows. Jog running > multi-step speed, keyboard settings or analog settings or communications settings.

Function Code	Name	Description	Setting Range	Factory Setting
P1.20	Motor autotuning ACC time	0.1~3600.0s	0.1~3600.0	40.0s
P1.21	Motor autotuning DEC time	0.1~3600.0s	0.1~3600.0	40.0s
P1.22	Slow running frequency	0.00~P0.03	0.00~P0.03	5.00Hz
P1.23	Slow running ACC/DEC time	0.0~3600.0s	0.0~3600.0	20.0s

Set slow running frequency and ACC/DEC time. When inverter receives "slow running" signal from the input terminals, it runs under the slow running speed.

Function Code	Name	Description	Setting Range	Factory Setting
P1.24	Forced deceleration time	0.1~3600.0s	0.1~3600.0	2.0s

Set forced deceleration time. When inverter receives "forced deceleration" signal from the input terminals, the speed reduces to 0 within this deceleration time.

Function Code	Name	Description	Setting Range	Factory Setting
P1.25	Stop mode	0: Deceleration to stop 1: Coast to stop	0~1	1

0: Deceleration to stop

When the stop command takes effect, the inverter decreases the output frequency according to P1.05 and the selected acceleration/deceleration time till stop.

1: Coast to stop

When the stop command takes effect, the inverter blocks the output immediately. The motor coasts to stop by its mechanical inertia.

Function Code	Name	Description	Setting Range	Factory Setting
P1.26	Subsidiary motor acceleration time	0.0~3600.0s	0.0~3600.0	1.0s
P1.27	Subsidiary motor deceleration time	0.0~3600.0s	0.0~3600.0	1.0s

Set subsidiary motor ACC/DEC time when master-slave control, the time should be shorter than or equal to ACC/DEC time of the host motor.

Function Code	Name	Description	Setting Range	Factory Setting
P1.28	Reserved	0~65535	0~65535	0
P1.29	Reserved	0~65535	0~65535	0

6.3 P2 Group--Motor Parameters

Function Code	Name	Description	Setting Range	Factory Setting
P2.00	Inverter model	0:Asynchronous machine 1: Synchronous machine	0~1	0

Notice: Setting right type of motor before self-learning.

Function Code	Name	Description	Setting Range	Factory Setting
P2.01	Motor rated power	0.4~900.0kW	0.4~900.0	Depend on model
P2.02	Motor rated frequency	0.01~P0.03	0.01~P0.03	50.00Hz
P2.03	Motor rated speed	1~36000rpm	1~36000	1460rpm
P2.04	Motor rated voltage	0~500V	0~500	380V
P2.05	Motor rated current	0.1~2000.0	0.1~2000.0	Depend on model

Notice:

- In order to achieve superior performance, please set these parameters according to motor nameplate, and then perform autotuning.
- The power rating of inverter should match the motor. If the bias is too big, the control performances of inverter will be deteriorated distinctly.
- Reset P2.01 can initializes P2.07~P2.11 automatically.

Function Code	Name	Description	Setting Range	Factory Setting
P2.06	Motor power factor	0.05~1.00	0.05~1.00	0.86

When the motor is autotuning, setting the parameter can optimize the motor control performance.

Function Code	Name	Description	Setting Range	Factory Setting
P2.07	Motor stator resistance	0.001~65.535Ω	0.001~65.535	Depend on model
P2.08	Motor rotor resistance	0.001~65.535Ω	0.001~65.535	Depend on model
P2.09	Motor leakage inductance	0.1~6553.5mH	0.1~6553.5	Depend on model
P2.10	Motor mutual inductance	0.1~6553.5mH	0.1~6553.5	Depend on model
P2.11	Current without load	0.1~6553.5A	0.1~6553.5	Depend on model

After autotuning, the value of P2.07~P2.11 will be automatically updated.

Notice: Do not change these parameters; otherwise it may deteriorate the control performance of inverter.

Function Code	Name	Description	Setting Range	Factory Setting
P2.12	Magnetic pole initial position	0.00~360.00	0.00~360.00	0.00
P2.13	Magnetic pole position amplitude gain	0.50~1.50	0.50~1.50	1
P2.14	C-phase magnetic pole position bias	0~9999	0~9999	433
P2.15	D-phase magnetic pole position bias	0~9999	0~9999	433

P2.12~P2.15 is valid only for synchronous motor.

Function Code	Name	Description	Setting Range	Factory Setting
P2.16	Motor weak magnetic coefficient	0.1~2.0	0.1~2.0	1.0
P2.17	Motor minimum weak magnetic limit	10.0~80.0	10.0~80.0	20.0

Motor is used under weak magnetic control.

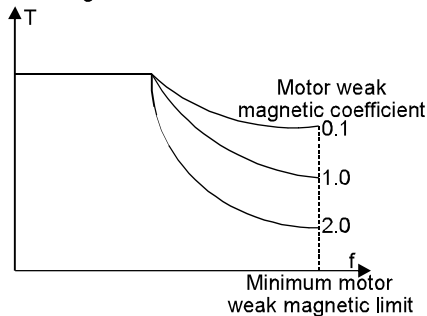

Figure 6.5 Motor weak magnetic

Function code P2.16 and P2.17 are valid for close loop vector control. When motor speed

is higher than rated speed, the motor is running into the weak magnetism. By modifying the weak magnetism control coefficient can change the curvature of weak magnetic curve, the greater of P2.16 the steeper of weak magnetic curve becomes, the smaller of P2.16 the flatter weak magnetic curve becomes.

Function Code	Name	Description	Setting Range	Factory Setting
P2.18	Weak magnetic proportion	0~65535	0~65535	0

Appropriate adjustments of this parameter can improve the motor performance when motor is working under weak magnetic control. The adjusting range is 2000~5000.

Function Code	Name	Description	Setting Range	Factory Setting
P2.19	Low-frequency oscillation suppression tolerance	0~10	0~10	2
P2.20	High-frequency oscillation suppression tolerance	0~10	0~10	0

When oscillation occurs under autotuning or V/F mode, the parameter should be adjusted.

Function Code	Name	Description	Setting Range	Factory Setting
P2.21	Motor output maximum voltage	P2.04~550V	P2.04~550	380V

Set the output maximum voltage of motor during the weak magnetic state.

Function Code	Name	Description	Setting Range	Factory Setting
P2.22	Motor switching type	1. Keypad 2. Profibus-DP 3. External terminal	0~2	0
P2.23	Keypad selection of motor parameters	0. Motor 0 parameters 1. Motor 1 parameters 2. Motor 2 parameters 3. Motor 3 parameters	0~3	0

6.4 P3 Group--Vector Control

Function Code	Name	Description	Setting Range	Factory Setting
P3.00	ASR low-speed proportional gain	0~100	0~100	20
P3.01	ASR low-speed integral time	0.01~10.00s	0.01~10.00	0.50s
P3.02	Speed detection low-speed filter time	0.000~3.000s	0.000~3.000	0.000s
P3.03	Low switching frequency	0.00Hz~P3.05	0.00~P3.05	5.00Hz
P3.04	ASR high-speed proportional gain	0~100	0~100	25
P3.05	ASR low-speed integral time	0.01~10.00s	0.01~10.00	1.00s
P3.06	Speed detection high-speed filter time	0.000~3.000s	0.000~3.000	0.000s
P3.07	High switching frequency	P3.03~P0.04	P3.03~P0.04	10.00HZ

P3.00~P3.07 are only valid for vector control and torque control and invalid for V/F control. Through P3.00~P3.07, user can set the proportional gain K_p and integral time K_i of speed regulator (ASR), so as to change the speed response characteristic. ASR's structure is shown in following figure.

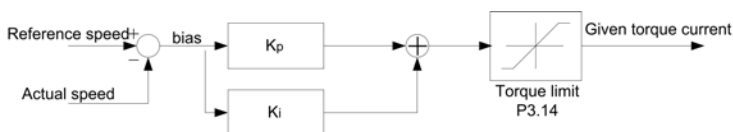

Figure 6.6 ASR diagram.

P3.00 and P3.01 only take effect when output frequency is less than P3.03. P3.04 and P3.05 only take effect when output frequency is greater than P3.07. When output frequency is between P3.03 and P3.07, K_p and K_i are proportional to the bias between P3.03 and P3.07. For details, please refer to following figure.

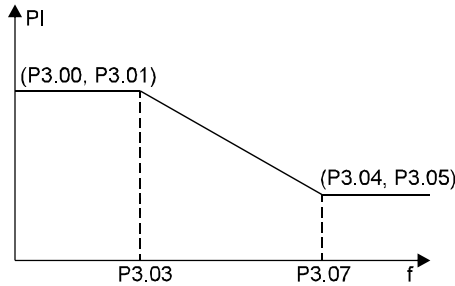

Figure 6.7 PI parameter diagram.

The system's dynamic response can be faster if the proportion gain K_p is increased; However, if K_p is too large, the system tends to oscillate.

The system dynamic response can be faster if the integral time K_i is decreased; However, if K_i is too small, the system becomes overshoot and tends to oscillate.

P3.00 and P3.01 are corresponding to K_p and K_i at low frequency, while P3.04 and P3.05 are corresponding to K_p and K_i at high frequency. Please adjust these parameters according to actual situation. The adjustment procedure is as follow:

1. Increase the proportional gain (K_p) as far as possible without creating oscillation.
2. Reduce the integral time (K_i) as far as possible without creating oscillation.

For more details about fine adjustment, please refer to description of P9 group.

P3.02 and P3.06 is the time for motor speed detection filter time. Under normal circumstances don't need to adjust, but in larger interference occasion need to set the time appropriately.

Function Code	Name	Description	Setting Range	Factory Setting
P3.08	ACR proportional gain P	0~65535	0~65535	500
P3.09	ACR integral gain I	0~65535	0~65535	500

The bigger the proportional gain P, the faster the response, but oscillation may easily occur. If only proportional gain P is applied in regulation, the bias cannot be eliminated. In order to eliminate the bias, apply the integral gain I to achieve PI regulator.

Function Code	Name	Description	Setting Range	Factory Setting
P3.10	Driver side slip compensation coefficients	50~200%	50~200	100%

Function Code	Name	Description	Setting Range	Factory Setting
P3.11	Braking side slip compensation coefficients	50~200%	50~200	100%

Slip compensation coefficients is used to adjust slip frequency of vector control and improve control accuracy of system speed. Adjust the parameters appropriately, speed static error can be restrained effectively. These settings are valid for both electric state and regenerative braking states.

Function Code	Name	Description	Setting Range	Factory Setting
P3.12	Torque setting source	0: Disabled 1: Keypad 2: AI1 3: AI2 4: 485 communication 5: Profibus communication 6: HDI 7: Subsidiary machine inside setting	0~7	0
P3.13	Keypad torque setting	-100.0~100.0%	-100.0~100.0	50.0%
P3.14	Torque limit	0.0~200.0%	0.0~200.0	150.0%

0: Torque control is disabled. Inverter will run at speed control mode. Output torque of inverter which should not greater than torque limit (P3.14) matches the torque of load automatically. When the torque of load is greater than torque limit, output torque will remain as torque limit and output frequency will decrease automatically.

1~7: Torque control is enabled.

When torque control takes effect,

If $T_{set} > T_{load}$, output frequency will increase continuously until it reaches upper frequency limit.

If $T_{set} < T_{load}$, output frequency will decrease continuously until it reaches lower frequency limit.

Inverter can run at any frequency between upper and lower frequency limit only when $T_{set} = T_{load}$.

Function Code	Name	Description	Setting Range	Factory Setting
P3.15	Torque limit method selection	0: Keypad(maximum torque is set up by P3.14) 1: Profibus	0~1	0
P3.16	Torque control prohibition access selection	0: Torque control prohibition is invalid 1: Terminal torque control prohibition is valid 2: Profibus torque control prohibition is valid 3: Both controls are valid	0~3	0

This function of P3.16 is mainly used in inverter torque control mode to achieve the switch between speed control mode and torque control mode.

0: Torque control prohibition is invalid

As long as P3.12 \neq 0, torque control is valid.

1: Terminal torque control prohibition is valid

When P3.12 \neq 0, terminal function can be used to prohibit torque control.

2: Profibus torque control prohibition is valid

The terminal torque control prohibition is invalid when P3.16 = 2.

3: Both controls are valid

Function Code	Name	Description	Setting Range	Factory Setting
P3.17	Forward torque upper frequency limit	0.00~P0.03	0.00~P0.03	50.00HZ

This function is used to set the maximum frequency when torque control.

Function Code	Name	Description	Setting Range	Factory Setting
P3.18	Forward torque upper frequency limit	0: Keyboard 1: AI1 2: AI2 3: HDI 4: 485 Communications 5: Profibus communication	0~5	0

When Forward torque upper frequency limit is 0, maximum frequency is set by the function code P3.17.

Function Code	Name	Description	Setting Range	Factory Setting
P3.19	Reverse torque upper frequency limit	0.00~P0.03	0.00~P0.03	50.00HZ
P3.20	Reverse torque upper frequency limit	0: Keypad 1: AI1 2: AI2 3: HDI 4: 485 communication 5: Profibus-DP	0~5	0
P3.21	Proportional coefficient of high frequency current loop	0~65535	0~65535	1000
P3.22	Integral coefficient of high frequency current loop	0~65535	0~65535	500
P3.23	Torque boost	0.0~10.0	0.0~10.0	0.0%
P3.24	Torque boost upper limited frequency	0.0~50.0%	0.0~50.0%	20.0%

Torque boost is valid under P3.24. Please refer to V/F curve of figure 6.8 as below to improve low frequency V/F torque characteristic.

According to load to select torque boost value.

Increase torque for big load, but the torque boost can not be set too big. Because the torque boost increasing too much will make the motor over excitation, the inverter output current will be big which will cause the motor increasing heating dissipation, reduce the efficiency. If P3.23=0.0%, the inverter torque output boosts automatically.

The inverter torque boost is valid when the frequency is less than P3.24. Otherwise, the torque boost will be invalid.

6.5 P4 Group--Encoder

Function Code	Name	Description	Setting Range	Factory Setting
P4.00	Encoder type	0: Incremental encoder 1: SIN/COS encoder 2: UVW encoder	0~2	0

Encoder wiring diagram please refer to figure 7.2 and 7.3.

Notice: P2.00 = 0 (asynchronous motor), incremental encoder is the only choice;
P2.00=1 (synchronous motor), SIN/COS and UVW-type encoders are valid.

Function Code	Name	Description	Setting Range	Factory Setting
P4.01	Encoder pulse	1~65535	1000	Depend on model
P4.02	Encoder direction	0~1	0~1	0

Notice: Encode parameters (P4.01) must be set properly under vector control with PG Card, otherwise the motor can't run properly. After encoder parameters setting, inverter still can't work, please change the encoder direction (P4.02).

Function Code	Name	Description	Setting Range	Factory Setting
P4.03	Low-speed, encoder disconnection detection time	0.0~100.0s	0.0~100.0	1.0s
P4.04	High-speed, encoder disconnection detection time	0.0~100.0s	0.0~100.0	1.0s
P4.05	Encoder reverse detection time	0.0~100.0s	0.0~100.0	1.0s

P4.03 and P4.04 defines encoder disconnection fault detection time, when the encoder disconnection time is longer than set time, inverter shows PCE, P4.03 corresponds to low-speed segment and P4.04 corresponds to high-speed segment.

P4.05 defines encoder reverse fault detection time, when the encoder reverse time is longer than corresponding reverses detection time, system shows PCDE.

Notice: The adjustment of these parameters will affect the sensitivity of the encoder fault protection, sometimes even appears abnormal movements, please carefully adjust.

Function Code	Name	Description	Setting Range	Factory Setting
P4.06	Position calculator conversion factor	10.0~6553.5	10.0~6553.5	10.0

This function is used to set location counter conversion factor (unit pulse),

Unit: pulses/mm.

Location counter conversion factor is calculated as follows:

The speed of crane is 60 m/min (60000 mm/min), corresponding motor speed is 1460 rpm.

The pulse number of encoder is 1000 ppr (parameter P4.01), the result of location counter conversion factor is $(1460 * 1000) / 60000 = 24.3$ pulses/mm.

Function Code	Name	Description	Setting Range	Factory Setting
P4.07	Reserved	0~65535	0~65535	0
P4.08	Reserved	0~65535	0~65535	0

6.6 P5 Group--Input Terminals

CHV190 series inverter comes with 6-channel multi-function digital input terminals, 2-channel analog input terminals. Please match I/O expansion cards to get more input/output terminals.

Function Code	Name	Description	Setting Range	Factory Setting
P5.00	HDI selection	0: HDI high speed pulse input. 1: ON/OFF input.	0~1	0

The function code P5.00 is used to define the input type HDI or ON/OFF signals.

Function Code	Name	Description	Setting Range	Factory Setting
P5.01	S4, S5 input type selection	0: ON/OFF 1: Master-slave synchronization counter	0~1	0

When S4 and S5 used as master-slave synchronization count input, S4 terminal should

connect to host PG card's division frequency output terminal, S5 terminal should connect to subsidiary PG card division frequency output terminal, and the common terminal of master and subsidiary motor divider cards should be shorten.

Notice: Choose master-slave synchronization count input, P5.05 and P5.06 should be modified to 0.

Function Code	Name	Description	Setting Range	Factory Setting
P5.02	S1 terminal function	Programmable multifunction terminal	0~40	1
P5.03	S2 terminal function	Programmable multifunction terminal	0~40	2
P5.04	S3 terminal function	Programmable multifunction terminal	0~40	6
P5.05	S4 terminal function	Programmable multifunction terminal	0~40	0
P5.06	S5 Terminal function	Programmable multifunction terminal	0~40	0
P5.07	HDI1 terminal function	Programmable multifunction terminal	0~40	0
P5.08	S7 terminal function	Programmable multifunction terminal	0~40	0
P5.09	S8 terminal function	Programmable multifunction terminal	0~40	0
P5.10	S9 terminal function	Programmable multifunction terminal	0~40	0
P5.11	S10 terminal function	Programmable multifunction terminal	0~40	0

The meaning of each setting is shown in following table.

Setting Value	Function	Description
0	Invalid	Please set unused terminals to be invalid to avoid malfunction.
1	Forward	When running command channel is terminal control, the crane is controlled by terminal.
2	Reverse	
3	Jog running	Inverter will work under Jog running state together with

Setting Value	Function	Description
		UP/DOWN signal when the terminal is selected to be Jog running
4	Low-speed running signal	When inverter receives low-speed running signal, if the current operating frequency is greater than low-speed running signal, the frequency will be slow to low-speed running frequency. If the inverter runs reversely, the speed will be accelerating to maximum in opposite direction.
5	Coast to stop	The inverter blocks the output immediately. The motor coasts to stop by its mechanical inertia.
6	Reset fault	Resets faults that have occurred. It has the same function as STOP/RST .
7	External fault input	Stop the inverter and output EF when peripheral device fault occurs
8~10	Multi-step speed terminals 1~3	By combination of the first-class speed contacts and three terminal state, eight-step speed can be realized.
11	Contact feedback signal (TB)	P8.04 selects contactor control valid, input terminal function is set to be 11 (contactor feedback signal). If the feedback signal is error, the inverter will show fault TbE.
12	Brake feedback signal (FB)	P8.04 selects brake control is valid, input terminal function is set into 12 (brake feedback signal). If the brake feedback signal is error, the inverter will show fault FAE.
13	Inverter enable (ENA)	When multi-function input terminal is set to be inverter enable, inverter can run only under ENA state.
14	Motor switching (MEX)	When inverter receives motor switching command, inverter runs under the parameters of second group motor in PC group.
15	Forced deceleration (FS)	When the inverter receives forced deceleration signal, the converter will slow down to zero according to forced slow time (P1.24).
16	Torque control prohibition	When P3.16 = 1, inverter can prohibit torque control through this function.
17	Motor excitation running	When the signal is valid, inverter will start motor excitation function.

Setting Value	Function	Description
18	Fast stop(FS)	When the signal is valid, inverter will stop according to the fast-stop mode (P8.32).
19	Master-slave synchronization enabled	When the inverter selects master-slave synchronization subsidiary mode (P0.11=9), the signal is valid, enable master-slave synchronization.
20	Master-slave synchronization count reset	When the inverter selects master-slave synchronization subsidiary mode (P0.11=9), the signal is valid, reset master-slave synchronization.
21	Light-load acceleration enable	When the inverter selects light-load acceleration function, the signal is valid, the inverter run under light-load acceleration optimized frequency.
22	UP command	The reference frequency of inverter can be adjusted by UP command and DOWN command.
23	DOWN command	
24	Zero position signal	Must check whether the operating rod back to zero position to prevent the inverter restart after the inverter stops (midpoint location). When the operating rod back to zero position, after the delay time (P8.49), the inverter can restart. Notice: Zero position signal is effective in the operating lever mode and hierarchical operating lever mode.
25~29	Classification given terminal 1~5	By combination of the first-class speed contact and five terminal states, sixteen-stage speed can be realized. Notice: Only when the lower-level multi-step speed classification contacts is all closed, higher-level classification contacts can be switch ON.
30~40	Reserved	0~65535

Function Code	Name	Description	Setting Range	Factory Setting
P5.12	Input mode selection	0~0xFF	0~0xFF	0

The selections of ON/OFF input terminals are normal open and normal closed. When

corresponding bit is 1 means normal closed input, this parameter is set to hex, ON/OFF signal input corresponds to the table as follows:

BIT9	BIT8	BIT7	BIT6	BIT5
S10	S9	S8	S7	HDI
BIT4	BIT3	BIT2	BIT1	BIT0
S5	S4	S3	S2	S1

Function Code	Name	Description	Setting Range	Factory Setting
P5.13	Input selection	0: Concrete. 1: Virtual.	0~1	0
P5.14	ON-OFF filter times	1~10	1~10	5

This parameter is used to set filter strength of terminals (S1~S10). When interference is heavy, user should increase this value to prevent malfunction.

Function Code	Name	Description	Setting Range	Factory Setting
P5.15	A11 lower limit	0.00V~10.00V	0.00~10.00	0.00V
P5.16	A11 lower limit corresponding setting	-100.0%~100.0%	-100.0~100.0	0.0%
P5.17	A11 upper limit	0.00V~10.00V	0.00~10.00	10.00V
P5.18	A11 upper limit corresponding setting	-100.0%~100.0%	-100.0~100.0	100.0%
P5.19	A11 filter time constant	0.00s~10.00s	0.00~10.00	0.10s

These parameters determine the relationship between analog input voltage and the corresponding setting value. When the analog input voltage exceeds the range between lower limit and upper limit, it will be regarded as the upper limit or lower limit.

The analog input A11 can only provide voltage input, and the range is 0V~10V.

For different applications, the corresponding value of 100.0% analog setting is different.

For details, please refer to description of each application.

Notice: A11 lower limit must be less or equal to A11 upper limit.

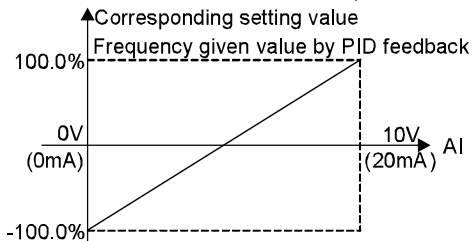

Figure 6.8 Relationship between AI and corresponding setting.

Function Code	Name	Description	Setting Range	Factory Setting
P5.20	AI2 lower limit	0.00V~10.00V	0.00~10.00	0.00V
P5.21	AI2 lower limit corresponding setting	-100.0%~100.0%	-100.0~100.0	0.0%
P5.22	AI2 upper limit	0.00V~10.00V	0.00~10.00	5.00V
P5.23	AI2 upper limit corresponding setting	-100.0%~100.0%	-100.0~100.0	100.0%
P5.24	AI2 filter time constant	0.00s~10.00s	0.00~10.00	0.10s

Please refer to description of AI1.

Notice: When AI2 is set as 0~20mA current input, the corresponding voltage range is 0~5V.

Function Code	Name	Description	Setting Range	Factory Setting
P5.25	HDI1 lower limit	0.0 kHz ~50.0kHz	0.0~50.0	0.0kHz
P5.26	HDI1 lower limit corresponding setting	-100.0%~100.0%	-100.0~100.0	0.0%
P5.27	HDI1 upper limit	0.0 kHz ~50.0kHz	0.0~50.0	50.0kHz
P5.28	HDI1 upper limit corresponding setting	-100.0%~100.0%	-100.0~100.0	100.0%
P5.29	HDI1 filter time constant	0.00s~10.00s	0.00~10.00	0.10s

The description of P5.25~P5.29 is similar to AI1.

Function Code	Name	Description	Setting Range	Factory Setting
P5.30~P5.35	Reserved	0~65535	0~65535	0

6.7 P6 Group--Output Terminals

Function Code	Name	Description	Setting Range	Factory Setting
P6.00	HDO selection	0: High-speed pulse output 1: ON-OFF output	0~1	0

0: High-speed pulse output: The maximum pulse frequency is 50.0 kHz. Please refer to description of P6.09.

1: ON-OFF output: Please refer to description of P6.03.

Notice: The output of HDO terminal is multi-function ON-OFF output.

Function Code	Name	Description	Setting Range	Factory Setting
P6.01	Y1 output selection	Open-collector output	0~20	1
P6.02	Y2 output selection	Open-collector output	0~20	0
P6.03	HDO ON-OFF output selection	Open-collector output	0~20	0
P6.04	Relay 1 output selection	Relay output	0~20	4
P6.05	Relay 2 output selection	Relay output	0~20	5
P6.06	Relay 3 output selection	Relay output	0~20	0

OC/Relay output functions are indicated in the following table:

Setting Value	Function	Description
0	No output	Output terminal has no function.
1	Motor running(LR)	ON: Inverter has output signal
2	UP running (UR)	ON: Crane up running
3	Down running (DR)	ON: Crane down running

Setting Value	Function	Description
4	Fault output	ON: Inverter is in fault status.
5	Zero speed running	ON: The running frequency of inverter is zero.
6	Ready	ON: Inverter is ready (no fault, power is ON).
7	Brake control	ON: Brake open; OFF: Brake closed
8	Contactor control	ON: Contactor open; OFF: Contactor closed
9	Frequency reached	Please refer to description of P6.24.
10	FDT reached	Please refer to description of P6.22~P6.23.
11	Motor running1 (LR1)	ON: Between brake open delay time end and close delay time end.
12	Brake closed output (FO)	ON: Brake closed delay time end until stop
13	Motor switching output	Feedback signal to the host after receive motor switch command
14	Motor excitation	When running commands and excitation signals are effective at the same time, the signal enabled until the exciting end
15	Motor excitation completion output	The signal is valid when the excitation process end
16	Sling loose alarm output	The signal is valid when the sling loose
17	High-speed signal output	When the inverter choose light-load function, operating frequency higher than the motor rated frequencies, the signal is effective.
18	Motor over temperature alarm output	When the temperature of motor exceeds the motor overtemperature threshold, output alarm
19~20	Reserved	Reserved

Notice: Multi-function output terminal 11, 12 is mainly used for: When the brake is in external control mode, inform control system brake.

Function Code	Name	Description	Setting Range	Factory Setting
P6.07	AO1 function selection	Multifunctional analog output	0~14	0
P6.08	AO2 function selection	Multifunctional analog output	0~14	0
P6.09	HDO function selection	Multifunctional high-speed pulse output	0~14	0

AO/HDO output functions are indicated in the following table:

Setting Value	Function	Range
0	Running frequency	0~maximum frequency (P0.07)
1	Reference frequency	0~ maximum frequency (P0.07)
2	Slope given frequency	0~ maximum frequency (P0.07)
3	Reserved	Reserved
4	Output current	0~2* inverter rated current
5	Output voltage	0~2* inverter rated voltage
6	Output power	0~2* rated power
7	Running torque	0~2* motor base synchronous speed
8	Output torque	0~2*rated torque
9	AI1	0~10V
10	AI2	0~10V/0~20mA
11	HDI1	0~10V
12~14	Reserved	Reserved

Function Code	Name	Description	Setting Range	Factory Setting
P6.10	AO1 lower limit	0.0~100.0%	0.0~100.0	0.0%
P6.11	AO1 lower limit corresponding output	0.00~10.00V	0.00~10.00	0.00V
P6.12	AO1 upper limit	0.0~100.0%	0.0~100.0	100.0%
P6.13	AO1 upper limit corresponding output	0.00~10.00V	0.00~10.00	10.00V

These parameters determine the relationship between analog output voltage/current and the corresponding output value. When the analog output value exceeds the range between lower limit and upper limit, it will output the upper limit or lower limit.

When AO is current output, 1mA is corresponding to 0.5V.

For different applications, the corresponding value of 100.0% analog outputs is different.

For details, please refer to description of each application.

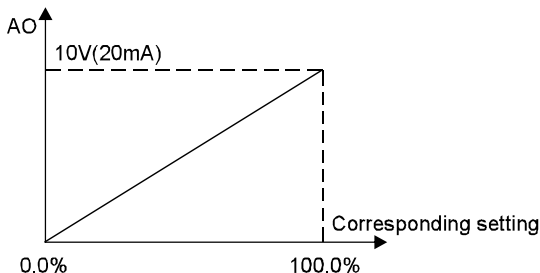

Figure 6.9 Relationship between AO and corresponding setting.

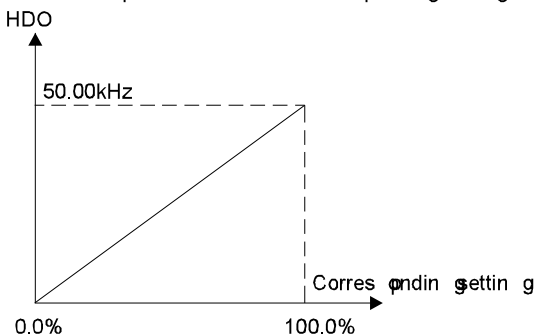

Figure 6.10 Relationship between HDO and corresponding setting.

Function Code	Name	Description	Setting Range	Factory Setting
P6.14	AO2 lower limit	0.0~100.0%	0.0~100.0	0.0%
P6.15	AO2 lower limit corresponding output	0.00~10.00V	0.00~10.00	0.00V
P6.16	AO2 upper limit	0.0~100.0%	0.0~100.0	100.0%
P6.17	AO2 upper limit corresponding output	0.00~10.00V	0.00~10.00	10.00V
P6.18	HDO lower limit	0.0~100.0%	0.0~100.0	0.0%

Function Code	Name	Description	Setting Range	Factory Setting
P6.19	HDO lower limit corresponding output	0.0~50.0kHz	0.0~50.0	0.0kHz
P6.20	HDO upper limit	0.0~100.0%	0.0~100.0	100.0%
P6.21	HDO upper limit corresponding output	0.0~50.0kHz	0.0~50.0	50.0kHz

The description of P6.18~P6.21 is similar to AO1.

Function Code	Name	Description	Setting Range	Factory Setting
P6.22	FDT level	0.00~P0.03	0.00~P0.03	50.00HZ
P6.23	FDT lag	0.0~100.0%	0.0~100.0	5.0%

Set output frequency detection value and output action lag value. See figure 6.11.

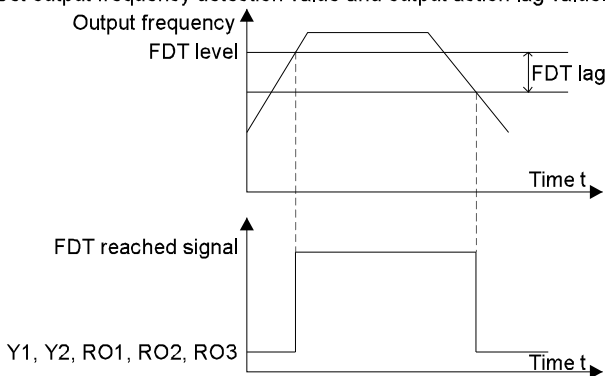

Figure 6.11 FDT level diagram

Function Code	Name	Description	Setting Range	Factory Setting
P6.24	Frequency arrive detecting range	0.0~100.0%	0.0~100.0	0.0%

The inverter output frequency reaches setting frequency; this function can adjust detecting range. See figure 6.12:

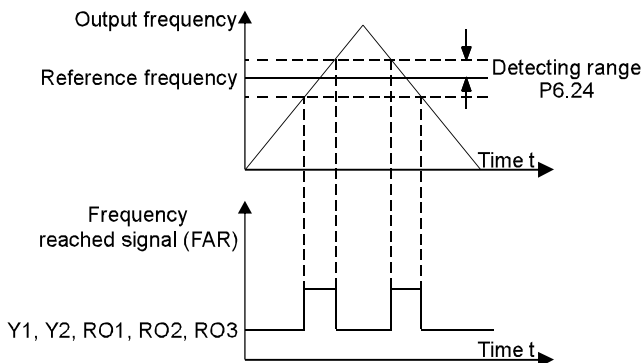

Figure 6.12 Frequency reached detection range diagram

Function Code	Name	Description	Setting Range	Factory Setting
P6.25	Reserved	0~65535	0~65535	0
P6.26	Reserved	0~65535	0~65535	0

6.8 P7 Group--Display Interface

Function Code	Name	Description	Setting Range	Factory Setting
P7.00	User password	0~65535	0~65535	0

The password protection function will be valid when set to be any nonzero data. When P7.00 is set to be 00000, user's password set before will be cleared and the password protection function will be disabled.

After the password has been set and becomes valid, the user can not access menu if the user's password is not correct. Only when a correct user's password is input, the user can see and modify the parameters. Please keep user's password in mind.

Function Code	Name	Description	Setting Range	Factory Setting
P7.01	Reserved	0~1	0~1	0
P7.02	Reserved	0~1	0~1	0
P7.03	QUICK/JOG function selection	0: Jog 1: FDW/REV switching	0~1	0

Parameter setting defines **QUICK/JOG** function, this function is only valid when the keyboard controls.

Function Code	Name	Description	Setting Range	Factory Setting
P7.04	STOP/RST function selection	0: Valid when keypad control (P0.01=0) 1: Valid when keypad or terminal control (P0.01=0 or 1) 2: Valid when keypad or communication control (P0.01=0 or 2) 3: Always valid	0~3	0

Notice:

- The value of P7.04 only determines the STOP function of **STOP/RST**.
- The RESET function of **STOP/RST** is always valid.

Function Code	Name	Description	Setting Range	Factory Setting
P7.05	Motor temperature			

The function code display motor temperature.

Function Code	Name	Description	Setting Range	Factory Setting
P7.06	Running status display selection	0~0xFFFF	0~0xFFFF	0x0003

P7.06 defines the parameters that can be displayed by LED in running status. If Bit is 0, the parameter will not be displayed; If Bit is 1, the parameter will be displayed.

Press **>>/SHIFT** to scroll through these parameters in right order .

Press **DATA/ENT** + **QUICK/JOG** to scroll through these parameters in left order.

The display content corresponding to each bit of P7.06 is described in the following table:

BIT15	BIT14	BIT13	BIT12	BIT11	BIT10
Reserved	Reserved	Reserved	Reserved	Reserved	Reserved
BIT9	BIT8	BIT7	BIT6	BIT5	BIT4
Magnetic pole position	Torque Compensation	HDI frequency	AI2	AI1	Output terminal status
BIT3	BIT2	BIT1	BIT0		
Input terminal status	Output torque	Output power	Rotation speed		

Input/output terminal status display inverter input/output terminal signal status at current time, close corresponds to 1, disconnection corresponds to 0. The entire data is displayed as Decimal. Please refer to P7.19, P7.20 for specific description.

Function Code	Name	Description	Setting Range	Factory Setting
P7.07	Stop status display selection	0x0001~0xFFFF	0x0001~0xFFFF	0x00FF

P7.07 determines the display parameters in stop status. The setting method is similar with P7.06.

The display content corresponding to each bit of P7.07 is described in the following table:

BIT15	BIT14	BIT13	BIT12	BIT11	BIT10
Reserved	Reserved	Reserved	Reserved	Reserved	Reserved
BIT9	BIT8	BIT7	BIT6	BIT5	BIT4
Reserved	HDI frequency	AI2	AI1	motor pole pairs	Output terminal status
BIT3	BIT2	BIT1	BIT0		
Input terminal status	DC bus voltage	Fault code	Reference frequency		

Function Code	Name	Description	Setting Range	Factory Setting
P7.08	Rectifier module temperature	0~150.0℃		
P7.09	IGBT module temperature	0~150.0℃		
P7.10	MCU software version			
P7.11	DSP software version			
P7.12	Accumulated running time	0~65535h		

Rectifier module temperature: Indicates the temperature of rectifier module. Overheat protection point of different inverter may be different.

IGBT module temperature: Indicates the temperature of IGBT module. Overheat protection point of different inverter may be different.

MCU software version: Indicates current software version of MCU.

DSP software version: Indicates current software version of DSP

Accumulated running time: Displays accumulated running time of inverter.

Notice: Above parameters are read only.

Function Code	Name	Description	Setting Range	Factory Setting
P7.13	Third latest fault type	0~50	0~50	0
P7.14	Second latest fault type	0~50	0~50	0
P7.15	Latest fault type	0~50	0~50	0

These parameters record three recent fault types. For details, please refer to description of chapter 7.

Function Code	Name	Description	Setting Range	Factory Setting																				
P7.16	Output frequency at current fault	Output frequency at current fault.		0																				
P7.17	Output current at current fault	Output current at current fault.																						
P7.18	DC bus voltage at current fault	DC bus voltage at current fault.																						
P7.19	Input terminal status at current fault	This value records ON-OFF input terminal status at current fault. The meaning of each bit is as below: <table border="1" style="margin: 10px auto;"> <tr> <td>9</td><td>8</td><td>7</td><td>6</td><td>5</td><td>4</td><td>3</td><td>2</td><td>1</td><td>0</td> </tr> <tr> <td>S10</td><td>S9</td><td>S8</td><td>S7</td><td>HDI1</td><td>S5</td><td>S4</td><td>S3</td><td>S2</td><td>S1</td> </tr> </table> 1 indicates corresponding input terminal is ON, while 0 indicates OFF. <p>Notice: This value is displayed as decimal.</p>	9	8	7	6	5	4	3	2	1	0	S10	S9	S8	S7	HDI1	S5	S4	S3	S2	S1		
9	8	7	6	5	4	3	2	1	0															
S10	S9	S8	S7	HDI1	S5	S4	S3	S2	S1															

Function Code	Name	Description	Setting Range	Factory Setting												
P7.20	Output terminal status at current fault	This value records output terminal status at current fault. The meaning of each bit is as below: <table border="1" style="margin-left: auto; margin-right: auto;"> <tr> <td>BIT5</td> <td>BIT4</td> <td>BIT3</td> <td>BIT2</td> <td>BIT1</td> <td>BIT0</td> </tr> <tr> <td>RO3</td> <td>RO2</td> <td>RO1</td> <td>HDO</td> <td>Y2</td> <td>Y1</td> </tr> </table> 1 indicates corresponding output terminal is ON, while 0 indicates OFF. Notice: This value is displayed as decimal.	BIT5	BIT4	BIT3	BIT2	BIT1	BIT0	RO3	RO2	RO1	HDO	Y2	Y1		
BIT5	BIT4	BIT3	BIT2	BIT1	BIT0											
RO3	RO2	RO1	HDO	Y2	Y1											
P7.21	Inverter rated power															
P7.22	Inverter rated current															

6.9 P8 Group--Enhanced Function

Function Code	Name	Description	Setting Range	Factory Setting
P8.00	Pre-torque signal input selection	0: No function 1: AI1 2: AI2 3: Profibus communication given 4: The internal dynamic given	0~4	0

Pre-torque compensation can provide torque corresponding to the weight of the load to avoid pulling carts or sliding down vehicle at the starting.

Notice: P8.00 and P0.02 can't use the same one analog input.

Function Code	Name	Description	Setting Range	Factory Setting
P8.01	Pre-torque offset	-100.0~100.0%	-100.0~100.0	0.0%
P8.02	Drive gain	0.000~7.000	0.000~7.000	1.000
P8.03	Brake gain	0.000~7.000	0.000~7.000	1.000

When crane starts, the pre-torque compensate the lifting weights appropriately which can improve the starting performance. Only when P8.00 is not set to 0, the pre-torque compensation is valid.

Function Code	Name	Description	Setting Range	Factory Setting
P8.04	Brake, contactor control selection	0~3	0~3	0~3

0: Brake and contactor are controlled by external controller, not by inverter.

1: Brake is controlled by inverter, and contactor is controlled by external controller.

2: Brake is controlled by external controller, and contactor is controlled by inverter.

3: Both brake and contactor is controlled by inverter.

Function Code	Name	Description	Setting Range	Factory Setting
P8.05	Delay time of brake closed	0.00~5.00s	0.00~5.00	0s
P8.06	Delay time of brake open	0.00~5.00s	0.00~5.00	0s

Delay time of brake closed contains the time between the command output of brake closed and the inverter output frequency reaching P8.09.

Delay time of brake open is from the zero speed running to the command output of brake open. This parameter let inverter prevent starting concussion, before brake open.

Notice: P8.05 and P8.06 are effective at all times.

Function Code	Name	Description	Setting Range	Factory Setting
P8.07	Brake feedback detecting interval	0.1~5.0s	0.1~5.0	2.0s

After selecting brake control, the fault time of crane brake action is more than P8.07, inverter will report brake feedback fault (FAE).

Function Code	Name	Description	Setting Range	Factory Setting
P8.08	Contactor feedback detecting interval	0.1~5.0s	0.1~5.0	2.0s

After selecting contactor control, the fault time of crane contactor action is more than P8.08, inverter will report contactor feedback fault (TbE).

Function Code	Name	Description	Setting Range	Factory Setting
P8.09	Brake frequency when parking	0.00~5.00Hz	0.00~5.00	0.00Hz

This code is used to select the frequency point to close brake.

If $P8.05 \neq 0$, when the inverter output frequency reaches P8.09, the inverter output close brake signal after the delay time (P8.05), the multi-output signal (FO), the brake control (FC) also stops to output.

If $P8.05 = 0$, when the inverter output frequency reaches P8.09, the inverter brakes immediately.

Function Code	Name	Description	Setting Range	Factory Setting
P8.10	DC Braking current before start	0.0~120.0%	0.0~120.0	0.0%
P8.11	DC Braking time before start	0.0~50.0s	0.0~50.0	0.0s

When inverter starts, it performs DC braking according to P8.10 firstly, then start to accelerate after P8.11.

Notice:

- **DC braking is invalid when P8.10 is set to be 0.**
- **The value of P8.11 is the percentage of rated current of inverter. The bigger the DC braking current, the greater the braking torques.**

Function Code	Name	Description	Setting Range	Factory Setting
P8.12	Starting frequency of DC braking	0.00~P0.03	0.00~P0.03	0.00Hz
P8.13	Waiting time before DC braking	0.0~50.0s	0.0~50.0	0.0s
P8.14	DC braking current	0.0~120.0%	0.0~120.0	0.0%
P8.15	DC braking time	0.0~50.0s	0.0~50.0	0.0s

Starting frequency of DC braking: Starting the DC braking when the running frequency reaches starting frequency determined by P8.12 ($P1.25 = 0$), the inverter is considered as zero speed running; the close brake delay time begins counting.

Notice: DC braking is effective only for decelerating to stop; the inverter is considered as zero speed running when DC braking, Delay time of close brake and open brake are valid all the time.

Function Code	Name	Description	Setting Range	Factory Setting
P8.16	Inverter stop delay time	0.00~5.00s	0.00~5.00	0.00s

Inverter stop delay time is used to prevent the inverter slip phenomenon due to the unstable brake holding.

If P1.25=1, when the inverter runs in normal state and coast to stop, the inverter immediately brakes and blocks the output without delay time(P8.16); when the inverter is running to zero speed, brake and coast to stop, the inverter will block the output after the delay time (P8.16).

If P1.25=0, whenever deceleration stop, the inverter will brake and delay stop time(P8.16) and then block the output.

Function Code	Name	Description	Setting Range	Factory Setting
P8.17	Auto reset times	0~10	0~10	0
P8.18	Fault relay action	0: Disabled 1: Enabled	0~1	0
P8.19	Reset interval	0.1~100.0s	0.1~100.0	1.0s

Auto reset function can reset the fault in preset times and interval. When P8.17 is set to be 0, it means “auto reset” is disabled and the protective device will be activated in case of fault.

P8.18 defines if fault relay active or not during auto reset. If continuous production without interruption is needed, please set P8.18=0.

Notice:

The fault such as OUT 1, OUT 2, OUT 3, OH1 and OH2 cannot be reset automatically. If fault has not occurred for ten minutes after the fault is reset, inverter will automatically clear the previous times of auto reset.

Function Code	Name	Description	Setting Range	Factory Setting
P8.20	Brake threshold voltage	560.0~750.0V	560.0~750.0	700.0V

When the DC bus voltage is greater than the value of P8.20, the inverter will start dynamic

When the DC bus voltage is greater than the value of P8.20, the inverter will start dynamic braking.

Function Code	Name	Description	Setting Range	Factory Setting
P8.21	Two-phase / three-phase modulation	0: Two-phase modulation 1: Three-phase modulation	0~1	0

0: Two-phase modulation: the motor noise is smaller, but its temperature is higher. If you select this function, the inverter should be derated.

1: Three-phase modulation: the motor noise is bigger, but it has better restraint for the motor oscillation.

Function Code	Name	Description	Setting Range	Factory Setting
P8.22	Motor excitation enable	0~1	0~1	0
P8.23	Motor excitation time	0.004~5.000s	0.004~5.000	0.010s

If P8.22 is valid, the inverter must have motor excited at first and then it can work normally.

Excitation command can be used by profibus communication or the multi-function (17), only when the excitation command and the running command are effective at the same time then the excitation will be valid. When the exciting start, the inverter multi-function output terminal will output electrical excitation signal until the excitation process is completed.

P8.23 is the motor excitation process duration, when the time arrives; the inverter multi-function output terminal will send a signal for exciting end.

Function Code	Name	Description	Setting Range	Factory Setting
P8.24	Torque monitoring selection	0~1	0~1	0
P8.25	Speed deviation limit of torque fault	1.0~100.0%	1.0~100.0	3.0%
P8.26	Delay time of torque fault	0.2~10.0s	0.2~10.0	1.0s

Function Code	Name	Description	Setting Range	Factory Setting
P8.27	Blocking factor of acceleration deviation when ACC/DEC	110.0~500.0%	110.0~500.0	150.0%

This section will be used to monitor the motor torque and output the trip signal while motor torque fault.

P8.24 = 1, torque monitoring enabled. If the absolute value of speed deviation is higher than the value of P8.25 and the time is greater than the delay time of torque fault (P8.26), and then the inverter will be tripped due to the torque fault that display on the keyboard. If the actual motor speed change rate (differential) is higher than the value of P8.27 in acceleration/deceleration duration, torque fault protection will be blocked, and the inverter will not be tripped.

Function Code	Name	Description	Setting Range	Factory Setting
P8.28	Output torque of electric brake	0.0%~200.0%	0.0~200.0	180.0%
P8.29	Acceleration time of braking torque	0.000~9.000s	0.000~9.000	1.000s
P8.30	Braking torque ending frequency	0.00~30.00hz	0.00~30.00	0.1Hz
P8.31	Applying time of electric brake to fast stop	0.00~20.00s	0.00~20.00	2.00s
P8.32	Fast stop mode	0:The electric braking only 1: The electric brake and the mechanical brake 2: The mechanical brake only	0~2	0

This part is used to adjust fast stop for inverter.

When the P8.32= 0, the electric braking is valid only, the output torque of electric brake is set by P8.28, the brake torque acceleration time is set by P8.29. the electric braking torque is relative to the motor rated torque, the value the greater the brake faster. When the motor decelerates to be P8.30, the inverter output the brake close signal.

When the P8.32=1, the electric brake and mechanical brake are valid, the electric braking process is the same as the one P8.32 = 0, but when the motor decelerate to the value of (P8.30) or applying time of electric brake to fast stop reached (P8.31), the inverter output the brake close signal.

When the P8.32=2, that is, only with the mechanical brake, the inverter output brake close signal and stop.

Function Code	Name	Description	Setting Range	Factory Setting
P8.33	Torque verification enable	0~1	0~1	0
P8.34	Keypad setting of torque verification	0.0~100.0%	0.0~100.0	10.0%
P8.35	Torque verification fault delay time	0.0~10.0 s	0.0~10.0	0.5s

This section is used to verify the inverter torque module.

Torque verification confirm that the inverter's output torque reaches the value of P8.34 before the inverter open brake and starts running to reduce slip cart phenomenon. This function module is only valid for closed-loop vector control mode.

P8.33=1, torque verification enable. If the mechanical brake is valid, when the inverter output torque reaches a positive torque given by P8.34 (relative to motor rated torque), the validation is successful, the mechanical brake will be open, and the inverter implement the next step of the startup sequence; if the torque verification is unsuccessful, after torque verification fault delay time (P8.35), the inverter will output fault.

Function Code	Name	Description	Setting Range	Factory Setting
P8.36	Light-load speeding up enable	0~1	0~1	0
P8.37	Speeding up command selection	0: Automatic 1: Terminals 2: Communication	0~2	1
P8.38	Frequency fluctuation coefficient	0~100	0~100	0~100

Function Code	Name	Description	Setting Range	Factory Setting
P8.39	Speed turning point of constant power	0.0~200.0	0.0~200.0	100.0%
P8.40	Filtering time factor of load torque signal	0.0~10.0s	0.0~10.0	0.2s
P8.41	Torque autotuning selection without load	0~1	0~1	0
P8.42	Consumed torque by empty hook rising	0.0~150.0%	0.0~150.0	N/A
P8.43	Consumed torque by empty hook descent	0.0~150.0%	0.0~150.0	N/A
P8.44	Output torque limit of rising up	0~150.0%	0~150.0	100.0%
P8.45	Output torque limit of descent	0~150.0%	0~150.0	75.0%

This part is used to for the inverter speeding up with the light-load.

The function modules can only be used to drag potential load, which is usually used only for crane.

When the motor drags light loads, the inverter can run with the weak magnetic adjusting speed which is the addition that is consist of the motor rated speed (base speed) and additional motor speed, the maximum effective torque of motor will be reduced. In order to ensure providing enough torque to control the load in the speed scope of the weak magnetic, the maximum permitted speed should be calculated.

P8.36 = 1, Light-load speeding up is valid, P8.44 and P8.45 are output torque limit in forward/reverse direction, when the speed rise to point P8.39 (speed turning point of constant power), the module will calculate the maximum permitted speed, and then, if there is speeding up command and the frequency fluctuation coefficient is less than P8.38. The inverter will runs in accordance with calculated frequency.

Frequency fluctuation coefficient (P8.38) is got in the application test for calculating the

maximum permitted speed more accurate.

If the load jitter severe and can not speed up, P8.38 should be adjusted to be bigger.

If the load is relatively stable, P8.38 should be reduced.

Function Code	Name	Description	Setting Range	Factory Setting
P8.46	Sling loosening torque threshold	1.0~100.0%	1.0~100.0	3.0%
P8.47	Sling loosening alarm output enable in falling	0: Prohibition 1: Output alarm signal 2: Output alarm, shutdown and brake	0~2	0

That part is used to detect loosening of the sling by the inverter.

If the inverter output torque is less than sling loosening torque threshold (P8.46) in rising stage, the light-load speed up if the inverter is prohibited to prevent shock.

When the inverter detects the load torque falling down below value of P8.46 the sling loosening torque threshold value, the sling loosening detection will be output according to the setting of P8.47.

Notice: Please make sure the inverter should autotune without load before using the function of sling loosening output, the value of P8.46 should greater than P8.43.

Function Code	Name	Description	Setting Range	Factory Setting
P8.48	Operating lever zero position detection enable	0~1	0~1	0
P8.49	Operating lever zero position delay time	0.0~60.0s	0.0~60.0	0.3s

This part is used to detect operating lever zero position

When P8.48 = 1, Operating lever zero position detection is effective.

To prevent the inverter restart after inverter stopped, it is necessary to check the operating lever back to zero position (midpoint location). After the operating lever is back to zero location and the delay time P8.49 is passed, inverter can be restarted.

Notice: the zero position signals only can be use in operating lever mode, hierarchical mode of operating lever.

Function Code	Name	Description	Setting Range	Factory Setting
P8.50	Over-current stall protection	0~1	0~1	1
P8.51	Coefficient of over-current stall	100~200%	100~200	150%
P8.52	Frequency decreasing rate of over-current	0.00~50.00Hz/s	0.00~50.00	0.00 Hz/s

During acceleration of inverter, the actual motor speed rise rate may lower than the output frequency rise rate because of too big load. If no measures to take, inverter will trip caused by over-current.

The principle of over-current protection is to detect the output current of inverter during inverter operation and compare it with over-current stall threshold determined by P8.51. If it exceeds the value of P8.51 during acceleration, inverter will remain output frequency; if it exceeds the value of P8.51 during constant speed running, inverter will decrease output frequency. When output current of inverter is lower than the value of P8.51, inverter will continue to accelerate until output frequency reach frequency reference. Please refer to following diagram.

Function Code	Name	Description	Setting Range	Factory Setting
P8.53	DC bus overvoltage adjuster enable	0~1	0~1	0
P8.54	DC bus overvoltage acceleration point	70.0~97.0	70.0~97.0	75.0
P8.55	PID limit for output of adjuster	0.0~10.0	0.0~10.0	5.0%
P8.56	Acceleration proportional coefficient	0.00~5.00	0.00~5.00	0.005
P8.57	Acceleration integral coefficient	0.01~20.00	0.01~20.00	1.00s

Function Code	Name	Description	Setting Range	Factory Setting
P8.58	Acceleration integral result limit	0.0~10.0	0.0~10.0	2.0%
P8.59	Acceleration differential coefficient	0.01~20.00	0.01~20.00	0.00s

If P8.53=1, the DC bus overvoltage adjuster is enable.

The DC bus voltage exceeds the point P8.54, the adjuster begin to work. Adjust the DC bus voltage by adjusting the speed of motor, when the DC bus voltage exceeds P8.45, the motor speed will increase.

Function Code	Name	Description	Setting Range	Factory Setting
P8.60	PID voltage threshold of adjuster	65.0~P8.54	65.0~P8.54	70%
P8.61	Adjuster operational ways	0 .Dissipated by PID. 1. Converted to by current PID adjuster output value (Valid when slave mode is valid only).	0~1	0
P8.62	Integral coefficient of adjuster PID	0.01~20.00	0.01~20.00	3.00s
P8.63	Differential coefficient of adjuster PID	0.00~20.00	0.00~20.00	0.00s

If P8.53=1, when DC bus voltage is less than P8.60, the adjuster begin to work, adjust motor speed to regulate DC bus voltage. When the DC bus voltage is less than P8.60, slow down motor speed.

6.10 P9 Group--Protection Parameters

Function Code	Name	Description	Setting Range	Factory Setting
P9.00	Input phase-failure protection	0: Disabled 1: Enabled	0~1	1

Function Code	Name	Description	Setting Range	Factory Setting
P9.01	Output phase-failure protection	0: Disabled 1: Enabled	0~1	1

Notice: Please be cautious to set these parameters as disabled. Otherwise it may cause inverter and motor overheat even damaged.

Function Code	Name	Description	Setting Range	Factory Setting
P9.02	Motor overload protection	0: Disabled 1: Normal motor 2: Variable frequency motor	0~2	2

1: For normal motor, the lower the speed, the poorer the cooling effect. Based on this reason, if output frequency is lower than 30Hz, inverter will reduce the motor overload protection threshold to prevent normal motor from overheat.

2: As the cooling effect of variable frequency motor has nothing to do with running speed, it is not required to adjust the motor overload protection threshold.

Function Code	Name	Description	Setting Range	Factory Setting
P9.03	Motor overload protection current	20.0%~120.0%	20.0~120.0	100.0%

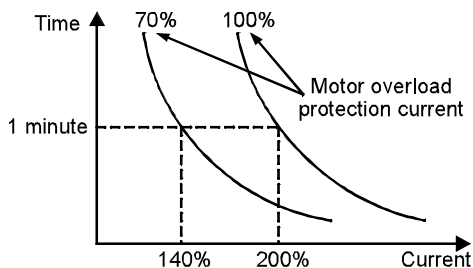

Figure 6.13 Motor overload protection curve.

he value can be determined by the following formula:

$$\text{Motor overload protection current} = (\text{motor rated current} / \text{inverter rated current}) * 100\%$$

Notice:

- This parameter is normally used when rated power of inverter is greater than rated power of motor.
- Motor overload protection time: 60s with 200% of rated current. For details,

please refer to above figure.

Function Code	Name	Description	Setting Range	Factory Setting
P9.04	Overload pre-warning threshold	20.0%~150.0%	20.0~150.0	130.0%
P9.05	Overload pre-warning selection	0: Always detect relative to motor rated current 1: Detect while constant speed relative to motor rated current 2: Always detect relative to inverter rated current 3: Detect while constant speed relative to inverter rated current	0~3	0
P9.06	Overload pre-warning delay time	0.0~30.0s	0.0~30.0	5.0s

The value of P9.05 determines the pre-warning category, such as motor overload (OL1) or inverter overload (OL2).

P9.04 determines the current threshold of pre-warning action, it is a percentage of the rated current. When output current of inverter exceeds the value of P9.04 and last the duration determined by P9.06, inverter will output a pre-warning signal. Please refer to following diagram:

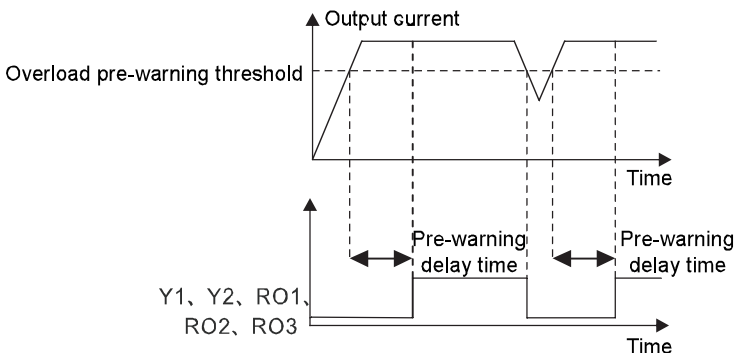

Figure 6.14 Overload pre-warning schematic diagram.

Function Code	Name	Description	Setting Range	Factory Setting
P9.07	Motor overspeed protection	0~1	0~1	0
P9.08	Overspeed protection point of motor 1	100.0~200.0%	100.0~200.0	110.0%
P9.09	Overspeed protection point of motor 2	100.0~200.0%	100.0~200.0	110.0%

This section is used to monitor the motor speed, the inverter will trip signal when the motor exceeds the given speed

Set P9.07=1 to enable motor overspeed protection. If the motor speed exceeds the setting of P9.08, the inverter will shutdown immediately and reported the fault OFE (enable the brakes at the same time), and the keyboard display the fault.

Function Code	Name	Description	Setting Range	Factory Setting
P9.10	Motor over-temperature protection	0: Disabled 1: Enabled	0~1	0
P9.11	Type of motor temperature sensor and signal source setting	0: PT100 1: PT1000	0~1	0
P9.12	Temperature adjusting bias	-80.0~80.0	-80.0~80.0	0.0℃

This section of P9.12 is used to set the temperature detecting bias. The setting is as follows:

If P9.11 is selected PT100, DIP switch is OFF, a value of 100Ω resistor is connected between the PT100 terminal and GND, and check the value of motor temperature display (P7.05), and temperature adjusting bias (P9.12) is the reverse of P7.05.

If P9.11 is selected PT1000, DIP switch is OFF, a value of 1kΩ resistor is connected between the PT100 terminal and GND

Notice: Using the motor over-temperature protection feature, you must select I/O expansion cards.

Function Code	Name	Description	Setting Range	Factory Setting
P9.13	Temperature correct factor	50.0~150.0	50.0~150.0	100.0%
P9.14	The motor1 over-temperature protection point	0~150.0	0~150.0	100.0℃

This feature code P9.14 is used to set the motor point of an over-temperature protection. If the motor temperature exceeds an the motor point of an over-temperature protection (P9.14), the inverter will immediately shutdown and report over-temperature fault OH3 (enable the brakes at the same time), and the keypad display the fault.

Function Code	Name	Description	Setting Range	Factory Setting
P9.15	The motor 1 over-temperature warning point	20.0~100.0%	20.0~100.0	90.0%

This feature code is used to set the motor point of an over-temperature warning. If the motor temperature exceeds the points of motor over-temperature warning (P9.15), the inverter will output the over-temperature warning signal.

Function Code	Name	Description	Setting Range	Factory Setting
P9.16	The motor 2 over-temperature protection point	0~150.0	0~150.0	100.0℃
P8.51	Coefficient of over-current stall	100~200%	100~200	150%

This feature code is used to set the motor 2 point of over-temperature protection.

Function is same to P9.14.

Function Code	Name	Description	Setting Range	Factory Setting
P9.17	The motor 2 over-temperature warning point	20.0~100.0%	20.0~100.0	90.0%

This feature code is used to set the motor 2 over-temperature warning points.

Functional description is same to P9.15.

Function Code	Name	Description	Setting Range	Factory Setting
P9.18	Motor temperature compensation enable	0: Disabled 1: Enabled	0~1	0

This section is used to compensate the impact of motor parameters altering at different temperature point; user should equip the electrical temperature sensor and the I/O expansion cards while using this function.

Function Code	Name	Description	Setting Range	Factory Setting
P9.19~P9.20	Reserved	0~65535	0~65535	0

6.11 PA Group--Serial Communication

Function Code	Name	Description	Setting Range	Factory Setting
PA.00	Local communication address	0~247	0~247	1

When the master is writing the frame, if the communication address of the slave is set to be 0 (that is the broadcast communication address), all slaves on the MODBUS bus will receive the frame, but the slaves will not make any response. Note that the slave address should not be set to be 0.

The local communication address is a unique address in the communication network. This is the basis for point-to-point communications between the upper computer and the inverter.

Function Code	Name	Description	Setting Range	Factory Setting
PA.01	Communication baud rate selection	0: 1200BPS 1: 2400BPS 2: 4800BPS 3: 9600BPS 4: 19200BPS 5: 38400BPS	0~5	4

This parameter is used to set the data transmission rate between the upper computer and the inverter.

Notice: The baud rate setting of the upper computer should be the same as that of the inverter. Otherwise, communications cannot be implemented. The higher the baud rate, the faster the communication speed is.

Function Code	Name	Description	Setting Range	Factory Setting
PA.02	Data format	0: No parity (8,N,2) for RTU 1: Even parity (8,E,1) for RTU 2: Odd parity (8,O,1) for RTU 3: No parity (8,N,2) for ASCII 4: Even parity (8,E,1) for ASCII 5: Odd parity (8,O,1) for ASCII 6: No parity (7,N,2) for ASCII 7: Even parity (7,E,1) for ASCII 8: Odd parity (7,O,1) for ASCII	0~8	1

The data format setting of the upper computer should be the same as that of the inverter. Otherwise, communications cannot be implemented.

Function Code	Name	Description	Setting Range	Factory Setting
PA.03	Communication reply delay	0~20ms	0~20	0ms

Reply delay: refers to the interval time between the end of data receiving of the inverter and the reply data sending of the upper computer. If the reply delay time is less than the system processing time, take the system processing time as reply delay reference. If the reply delay is longer than the system processing time, after data processing, the system has to wait until the reply delay time is reached before sending data to the upper computer.

Function Code	Name	Description	Setting Range	Factory Setting
PA.04	Communication timeout fault time	0.0~100.0s	0.0~100.0	0.0s

If the functional code is set to 0.0s, the communication delay time parameter is disabled. When the functional code is set to be a valid value, if the interval between the current communication and the next communication exceeds the communication delay time, the system will send a communication fault error (Err18).

Normally, it is set to be “disabled”. If this parameter is set in a consecutive communication system, communication status can be monitored.

Function Code	Name	Description	Setting Range	Factory Setting
PA.05	Communication reply enable	0: Communication reply enabled 1: Communication reply disabled	0~1	0
PA.06	Transmission error handling	0: Report fault and coast to stop 1: Do not report fault and continue running 2: Do not report fault and stop according to setting (communication valid only) 3: Do not report fault and stop according to setting (all of the control mode)	0~3	0

Select inverter operating status to shield CE fault and shut down or continuing running, in which way inverter can continue running when communication fault.

Function Code	Name	Description	Setting Range	Factory Setting
PA.07	RS485 communication protocol	0: Modbus protocol 1: Master-slave control protocol	0~1	0

Selecting 485 communication protocols, the standard modbus protocol should be set to 0, master-slave control protocol should be set to 1, or communication can not work.

Function Code	Name	Description	Setting Range	Factory Setting
PA.08	Ethernet communication speed setting	0: 10 M full-duplex 1: 10 M half-duplex 2: 100 M full-duplex 3: 100 M half-duplex 4: Adaptive	0~4	1

The feature code is used for the Ethernet communication speed settings.

Function Code	Name	Description	Setting Range	Factory Setting
PA.09	IP Address 1	0~255	0~255	192
PA.10	IP Address 2	0~255	0~255	168
PA.11	IP Address 3	0~255	0~255	0
PA.12	IP Address 4	0~255	0~255	1
PA.13	Subnet Mask 1	0~255	0~255	255
PA.14	Subnet Mask 2	0~255	0~255	255
PA.15	Subnet Mask 3	0~255	0~255	254
PA.16	Subnet Mask 4	0~255	0~255	0

This section is used to set the Ethernet IP address and subnet mask of communications.

IP Address format: PA.09, PA.10, PA.11, PA.12

For example: IP address is 192.168.0.1

IP Subnet Mask Format: PA.13, PA.14, PA.15, PA.16

For example: subnet mask is 255.255.255.0.

Function Code	Name	Description	Setting Range	Factory Setting
PA.17~PA.21	Reserved	0~65535	0~65535	0

This function is reserved.

Function Code	Name	Description	Setting Range	Factory Setting
PA.22	CAN Address	0~127	0~127	1

Set CAN Bus mailing address. Local address in the CAN bus communication network, is unique.

Function Code	Name	Description	Setting Range	Factory Setting
PA.23	CAN baud rate settings	0: 20K BPS 1: 50K BPS 2: 100K BPS 3: 250K BPS 4: 500K BPS 5: 1M BPS 5: 1M BPS	0~5	4

This parameter is used to set up the data transfer rate of CAN-bus between the two inverters.

Function Code	Name	Description	Setting Range	Factory Setting
PA.24	CAN communication timeout delay	0.0~100.0s	0.0~100.0	0s

When the function code is set to be 0.0s, PA.24 is invalid.

When the function code is set to be non-zero value, if the time between this communication and the next exceeds the communication timeout interval, the system will report communication fault (CANE). Usually this parameter is set to invalid. You can monitor the communication status by this parameter in continuous communication systems.

6.12 Pb Group--Master-Slave Control Group

Function Code	Name	Description	Setting Range	Factory Setting
Pb.00	Master-slave control mode selection	0: Stand-alone mode 1: Power balance mode 2: Speed synchronized mode	0~2	0

Power balance mode is a load distribution application for the system that is the shaft coupling applications of two motors through the gear box and rail. The Master sends signals and given value (speed and torque) to the slave through the communication bus. Speed synchronized mode is that two separated cranes lift the same load in one pace. The pulse encoder feedback and communication are necessary for the two inverters during

speed synchronized mode.

If Pb.00 \neq 0, the default communication of master-slave is CAN bus. If you want to use 485, please set PA.07=1.

Function Code	Name	Description	Setting Range	Factory Setting
Pb.01	Master-slave mode setting	0: Master-slave mode is invalid 1: This is the master 2: This is the slave 3: Master or slave is set by Profibus	0~3	0

If Pb.01=3, the Profibus-DP card is needed. One of the PZD receiver set to be 6 (master-slave mode selection). The master is 0x55aa, the slave is 0x66bb.

Notice: If Pb.01=3, When communication mode decides the master-slave mode, the master is sending, the slave is receiving without response.

Function Code	Name	Description	Setting Range	Factory Setting
Pb.02	Reference signal from master to slave	0: Master output torque 1: Master output current 2: Pulse counter of master encoder	0~2	0

0: Master output torque.

The reference signal of master to slave is the master output torque.

1: Master output current.

The reference signal of master to slave is the master output current.

2: Pulse counter of master encoder

This function is used master-slave speed synchronous mode commonly.

Function Code	Name	Description	Setting Range	Factory Setting
Pb.03	The interval of master sending data to slave	0~10000ms	0~10000	10ms

This function defines the interval of master sending data to slave every two times when master-slave function enables.

Function Code	Name	Description	Setting Range	Factory Setting
Pb.04	Master-slave communication channel selection	0: Prohibited communications 1: CAN communication 2: 485	0~2	0

This function is used to control the master to send or stop sending data to the slave at any time; or select receiving channel of slave.

Function Code	Name	Description	Setting Range	Factory Setting
Pb.05	The slave control source	0: Master communications control 1: According to P0.01 setting.	0~1	0
Pb.06	the slave reference frequency source	0: From the master communications 1: Selection though P0.02	0~1	0

When the master-slave control, the slave chooses the reference speed of the source through the feature code and the channel is the master speed.

Function Code	Name	Description	Setting Range	Factory Setting
Pb.07	The gain of the slave reference frequency source	0.01~100.00	0.01~100.00	1.00

The PID given of the slave synchronous speed is come from the multiplication of Pb.06 and Pb.07 during the master-slave control; it is more convenient for user to adjust the synchronous speed relationship of the master and slave.

Function Code	Name	Description	Setting Range	Factory Setting
Pb.08	the slave reference signal source	0: Master communications 1: AI1 2: AI2 3: HDI1	0~3	0

Function Code	Name	Description	Setting Range	Factory Setting
Pb.09	The gain of the slave reference signal source	0.01~100.00	0.01~100.00	1.00
Pb.10	Filtering time of the slave reference signal	0.0~3.0s	0.0~3.0s	0.0s

The PID given of the slave reference signal is come from the multiplication of Pb.08 and Pb.09 during the master-slave control; it is more convenient for user to adjust the synchronous speed relationship of the master and slave.

Function Code	Name	Description	Setting Range	Factory Setting
Pb.11	PID proportional coefficient 1	0.000~10.000	0.000~10.000	0.005
Pb.12	PID integral time 1	0.01~80.00s	0.01~80.00	8.00s
Pb.13	PID switching low point	0.00~Pb.16	0.00~Pb.16	5.00Hz
Pb.14	PID proportional coefficient 2	0.000~10.000	0.000~10.000	0.010
Pb.15	PID integral time 2	0.01~80.00s	0.01~80.00	10.00s
Pb.16	PID switching high point	Pb.13~P0.03	Pb.13~P0.03	10.00Hz
Pb.17	PID Differential time	0.00~10.00s	0.00~10.00	0.00s

- Reducing overshooting

If overshooting occurs, shorten the differential time and lengthen the integral time.

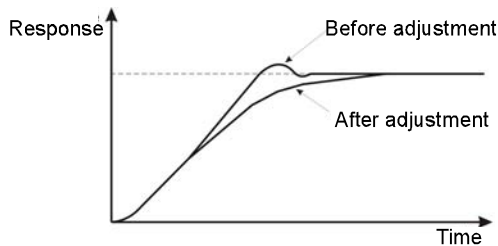

Figure 6.15 Reducing overshooting diagram.

- Rapidly stabilizing control status

To rapidly stabilize the control conditions even when overshooting occurs, shorten the integral time and lengthen the differential time.

- Reducing long-cycle oscillation

If oscillation occurs with a longer cycle than the integral time setting, it means that integral operation is strong. The oscillation will be reduced as the integral time is lengthened.

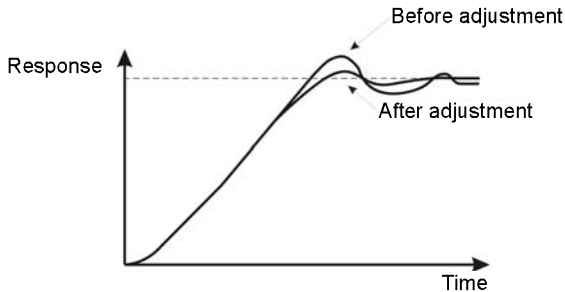

Figure 6.17 Reducing long-cycle oscillation diagram.

- Reducing short-cycle oscillation

If the oscillation cycle is short and oscillation occurs with a cycle approximately the same as the differential time setting, it means that the differential operation is strong. The oscillation will be reduced as the differential time is shortened.

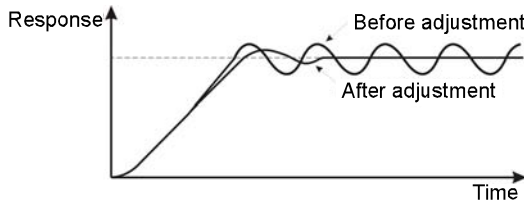

Figure 6.18 Reducing short-cycle oscillation diagram.

If oscillation cannot be reduced even by setting the differential time to 0, then either lowers the proportional gain or raise the PID primary delay time constant.

Function Code	Name	Description	Setting Range	Factory Setting
Pb.18	PID output filter time	0.00~10.00s	0.00~10.00	0.00s

The bigger the filter time, the better the immunity capability, but the response becomes slow, vice versa.

Function Code	Name	Description	Setting Range	Factory Setting
Pb.19	Integral result of limiting	0.0~100.0%	0.0~100.0	100.0%

The result of integral within the inverter will automatically be limited.

Function Code	Name	Description	Setting Range	Factory Setting
Pb.20	The results of integration	-100.0~100.0%	-100.0~100.0	Depend on model

The integration limiting result is showed for debugging and checking convenient.

Function Code	Name	Description	Setting Range	Factory Setting
Pb.21	Bias limit	0.0~80.0%	0.0~80.0	0.0%

Bias limit defines the maximum bias between the feedback and the preset. PID stops operation when the bias is within this range, setting this parameter correctly is helpful to improve the system output accuracy and stability.

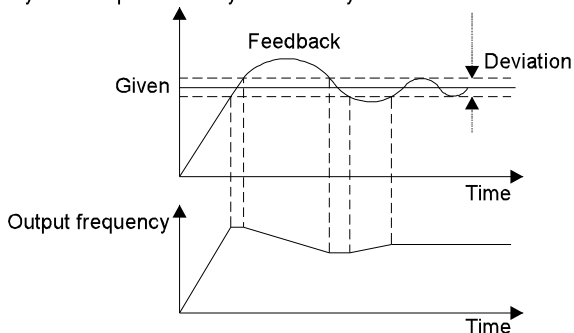

Figure 6.19 Relationship between bias limit and output frequency

Function Code	Name	Description	Setting Range	Factory Setting
Pb.22	PID regulation characteristics	0: Positive 1: Negative	0~1	0

Pb.22=0, the feedback value is greater than the preset value, output frequency will be decreased.

Pb.22=1, the feedback value is smaller than the preset value, output frequency will be increased.

Function Code	Name	Description	Setting Range	Factory Setting
Pb.23	PID mode selection	0~3	0~3	2

0: Take proportional-plus-integral result as a synchronization coefficient

PID output= PID preset*(the results of the proportion P+ the results of the integration I)

1: Take proportional coefficient of P as error correction, I as integral synchronous coefficient

PID output = PID preset *the results of the integration I+ the results of the proportion P

2: Take proportional coefficient P and Integral coefficient I as the error correction

PID output = PID preset+the results of the integration I + the results of the proportion P

3 only use the proportion

Function Code	Name	Description	Setting Range	Factory Setting
Pb.24	PID integration of lower synchronized speed limit	0.0~100.0%	0.0~100.0	0.0%

This function defines the slave PID calculation starting time. When the master synchronized speed reaches Pb.24. the slave begin the PID calculation. This function is used for slave synchronization when master starts firstly.

Function Code	Name	Description	Setting Range	Factory Setting
Pb.25	PID enabled	0: Disabled 1: Enabled.	0~1	0
Pb.26	Numerator of synchronized variable speed ratio	1~32000	1~32000	1000
Pb.27	Nominator of synchronized variable speed ratio	1~32000	1~32000	1000

When the master and the slave use gearboxes with different transmission ratio, you can set the mechanical speed ratio between the master and the slave through Pb.26 and

Pb.27.

The speed ratio of Master/slave = Pb.26/Pb.27, this speed rate is effective for the slave in the speed synchronous control.

Function Code	Name	Description	Setting Range	Factory Setting
Pb.28	limit of synchronous speed position error	0~50000	0~50000	1000

If the speed deviation between the master and slave is higher than Pb.28, the inverter will report to the master-slave speed synchronization fault.

Function Code	Name	Description	Setting Range	Factory Setting
Pb.29	Speed synchronous position deviation adjustment dead zone	0~20000	0~20000	50

When the master-slave speed synchronization control is effective, the synchronous speed deviation between the master and the slave exceeds the Pb.29, and then the slave regulates speed in accordance with setting.

Function Code	Name	Description	Setting Range	Factory Setting
Pb.30	The amplitude limiting of speed synchronous regulator	0.0~100.0%	0.0~100.0	5.0%

When the master-slave speed synchronization control is effective, this code is used to regulate the scope of gain of the slave.

Function Code	Name	Description	Setting Range	Factory Setting
Pb.31	the minimum speed of synchronous output enable	0.0~100.0%	0.0~100.0	2.0%

When you select the master-slave speed synchronization control, the speed is greater than Pb.31; the regulation of speed synchronization is effective.

Function Code	Name	Description	Setting Range	Factory Setting
Pb.32	Reset source of speed synchronous counter	0: Automatic 1: Terminals	0~1	0

If Pb.32=0, the speed of synchronous counter is reset to 0 when the slave shutdown;

If Pb.32=1, the slave counter return to 0 when terminal reset.

Function Code	Name	Description	Setting Range	Factory Setting
Pb.33	Reset terminal polarity of synchronous speed counter	0: Rising edge 1: Falling edge	0~1	0
Pb.34	Pulse counter source of synchronous speed	0: External terminal S4,S5 1: Internal encoder pulse counting	0~1	1
Pb.35	Reserved	0~65535	0~65535	0

6.13 PC Group--Motor Parameters 1

Function Code	Name	Description	Setting Range	Factory Setting
PC.00	Speed control mode 1	0: Sensorless vector control 1: Vector control With PG 2: V/F control	0~2	1
PC.01	Maximum frequency 1	10.00~400.00Hz	10.00~400.00	50.00Hz
PC.02	Motor rated speed power 1	0.4~900.0kW	0.4~900.0	Depend on model
PC.03	Motor rated speed frequency 1	0.01~400.00Hz	0.01~400.00	50.00Hz

Function Code	Name	Description	Setting Range	Factory Setting
PC.04	Motor rated speed 1	1~36000rpm	1~36000	1460rpm
PC.05	Motor rated speed voltage 1	1~480V	1~480	380V
PC.06	Motor basic speed current 1	0.1~2000.0A	0.1~2000.0	Depend on model
PC.07	Motor rated speed power factor 1	0.05~1.00	0.05~1.00	Depend on model
PC.08	Motor stator resistance 1	0.001~65.535Ω	0.001~65.535	Depend on model
PC.09	Motor rotor resistance 1	0.001~65.535Ω	0.001~65.535	Depend on model
PC.10	Motor leakage inductance 1	0.1~6553.5mH	0.1~6553.5	Depend on model
PC.11	Motor mutual inductance 1	0.1~6553.5mH	0.1~6553.5	Depend on model
PC.12	Current without load 1	0.01~655.35A	0.01~655.35	Depend on model
PC.13	Acceleration time 1	0.0~3600.0s	0.0~3600.0	20.0s
PC.14	Deceleration time 1	0.0~3600.0s	0.0~3600.0	20.0s
PC.15	Start section of acceleration S curve 1	0.1~50.0%	0.1~50.0	10.0%
PC.16	End section of acceleration S curve 1	0.1~50.0%	0.1~50.0	10.0%
PC.17	Start section of deceleration S curve 1	0.1~50.0%	0.1~50.0	10.0%
PC.18	End section of deceleration S curve 1	0.1~50.0%	0.1~50.0	10.0%

Function Code	Name	Description	Setting Range	Factory Setting
PC.19	Encoder type selection	0: Increment encoder 1: SIN/COS encoder 2: UVW encoder	0~2	0
PC.20	Encoder pulse counting 1	1~65535	1~65535	1000
PC.21	Encoder direction 1	0:forward 1:reverse	0~1	0
PC.22	Carrier frequency 1	1.0~16.0kHz	1.0~16.0	Depend on model
PC.23	ASR proportional gain K_p1	0~100	0~100	20
PC.24	ASR integral time K_i1	0.01~10.00s	0.01~10.00	0.50s
PC.25	Low speed detecting filter time 1	0.000~1.000s	0.000~1.000	0.000s
PC.26	ASR switching point 1	0.00Hz~PC.30	0.00~PC.30	5.00Hz
PC.27	ASR proportional gain K_p1	0~100	0~100	25
PC.28	ASR integral time K_i1	0.01~10.00s	0.01~10.00	1.0s
PC.29	High speed detecting filter time 1	0.000~1.000s	0.000~1.000	0.000s
PC.30	ASR switching point 1	PC.26~P0.03	PC.26~P0.0	10.00Hz
PC.31	ACR proportional gain P1	0~65535	0~65535	500
PC.32	ACR integral gain I1	0~65535	0~65535	500
PC.33	Motor weak magnetic 1	1.0~2.0	1.0~2.0	1.0

Function Code	Name	Description	Setting Range	Factory Setting
PC.34	Motor Minimum weak magnetic 1	10.0~80.0%	10.0~80.0	50.0
PC.35	The proportion of weak magnetic 1	0-65535	0-65535	0
PC.36	Low-frequency threshold of restraining oscillation 1	0~10	0~10	2
PC.37	High-frequency threshold of restraining oscillation 1	0~10	0~10	0
PC.38	Maximum motor output voltage 1	PC.05~550V	PC.05~550	380V
PC.39	HF-ACR proportional gain P1	0~65535	0~65535	1000
PC.40	HF-ACR integral gain I1	0~65535	0~65535	1000
PC.41	Slip compensation coefficient 1 of drive side	50~200	50~200	100%
PC.42	Slip compensation coefficient 1 of braking side	50~200	50~200	100%
PC.43	Torque upper limit current value 1	0.0~200	0.0~200	110%
PC.44	Motor overspeed point 1	0~200	0~200	110%
PC.45	Motor overtemperature 1	0~1	0~1	0
PC.46	Motor overtemperature	0.0~60.0	0.0~60.0	40.0℃

Function Code	Name	Description	Setting Range	Factory Setting
	threshold 1			
PC.47	Motor overtemperature prewarning threshold 1	20.0~100.0	20.0~100.0	90%
PC.48	Motor temperature compensation enable 1	0~1	0~1	0
PC.49	Motor temperature compensation initial threshold 1	0.0~60.0	0.0~60.0	40.0℃
PC.50	Motor temperature compensation coefficient 1	0.0~200.0	0.0~200.0	100
PC.51	Reserved	0~65535	0~65535	0
PC.52	Reserved	0~65535	0~65535	0
PC.53	Motor type 1	0~1	0~1	0
PC.54	Magnetic pole initial position 1	0.00~360.00	0.00~360.00	0
PC.55	Magnetic pole position amplitude gain 1	0.50~1.50	0.50~1.50	1
PC.56	C phase magnetic pole position bias 1	0~9999	0~9999	433
PC.57	D phase magnetic pole position bias 1	0~9999	0~9999	433

6.14 Pd Group--Profibus Communication

For more information, please refer to Profibus communication enable manual.

Function Code	Name	Description	Setting Range	Factory Setting
Pd.00	Module type	1:Profibus	1	Profibus

Function Code	Name	Description	Setting Range	Factory Setting
Pd.01	Module address	0~99	0~99	2
Pd.02	PZD2 receiving	0: Invalid	0~20	1
Pd.03	PZD3 receiving	1: Speed reference	0~20	2
Pd.04	PZD4 receiving	2: Traction reference	0~20	3
Pd.05	PZD5 receiving	3: The maximum current	0~20	0
Pd.06	PZD6 receiving	reference	0~20	0
Pd.07	PZD7 receiving	4: The starting pre-torque	0~20	0
Pd.08	PZD8 receiving	compensation value	0~20	0
Pd.09	PZD9 receiving	5: Torque upper limit	0~20	0
Pd.10	PZD10 receiving	frequency	0~20	0
Pd.11	PZD11 receiving	6: Master-slave mode	0~20	0
Pd.12	PZD12 receiving	selection	0~20	0
		7~20: Reserved		
Pd.13	PZD2 sending	0: Invalid	0~30	9
Pd.14	PZD3 sending	1: Running frequency	0~30	10
Pd.15	PZD4 sending	2: Reference speed rpm	0~30	11
Pd.16	PZD5 sending	3: DC bus voltage	0~30	6
Pd.17	PZD6 sending	4: Output voltage	0~30	7
Pd.18	PZD7 sending	5: Output current	0~30	5
Pd.19	PZD8 sending	6: Output torque percentage	0~30	0
Pd.20	PZD9 sending	7: Output power percentage	0~30	0
Pd.21	PZD10 sending	8: Frequency reference	0~30	0
Pd.22	PZD11 sending	9: Function code	0~30	0
		10: Reserved		
Pd.23	PZD12 sending	11: PG card position	0~30	0
		12: Input terminal status		
		13: Output terminal status		
		14: Torque compensation		
		15: Motor rated torque		
		16: Reference frequency of the slope		
		17: Pd.24		
		18~30: Reserved		

Function Code	Name	Description	Setting Range	Factory Setting
Pd.24	Temporary variable of PZD sending	0~65535	0~65535	0

PZD Data sending instruction:

No.	name	Description																				
1	Running frequency	Unit:Hz, Range: (-32767~32767),Example:5000=50.00Hz																				
2	Running speed	Unit:rpm, Range: (-32767 ~ 32767),Example:1000=1000 rpm																				
3	DC bus voltage	Unit:V,Range:(0~ 65535) Example:6000=600.0V																				
4	Ouput voltage	Drive voltage feedback,Unit:V,Range:(0~ 65535) Example:380=380V																				
5	Output current	Drive current feedback,Unit:A,Range: (0~ 65535) Example:1500=150.0A																				
6	Output torque	Unit:%, Range: (-2500~ 2500) Example500=50.0%, 100.0% is corresponding to speed at rated torque																				
7	Output power	Unit:%, Range: (-32767~ 32767) Example500=50.0%, 100.0% corresponding to motor rated power																				
8	Freqeucy setting absolute value	Unit:Hz,Range:(0~ 32767), Example:5000=50.00Hz																				
9	Fault code	Range: (0~ 65535),Corresponding to the function code of (P7.21~P7.23)																				
10	Reserved	Range: (0~ 65535)																				
11	PG Card position	Range:(0~ 65535)																				
12	Input terminal state	Range:(0 ~ 65535) is the decimal of input terminal state(binary). Example: 43(decimal)= 00101011(binary), which means S1, S2, S4, S6 is on <table border="1" style="margin-left: 20px; margin-top: 10px;"> <tbody> <tr> <td></td> <td>BIT8</td> <td>BIT7</td> <td>BIT6</td> <td>BIT5</td> </tr> <tr> <td></td> <td>HDI</td> <td>S8</td> <td>S7</td> <td>S6</td> </tr> <tr> <td></td> <td>BIT4</td> <td>BIT3</td> <td>BIT2</td> <td>BIT1</td> </tr> <tr> <td></td> <td>S5</td> <td>S4</td> <td>S3</td> <td>S2</td> </tr> </tbody> </table>		BIT8	BIT7	BIT6	BIT5		HDI	S8	S7	S6		BIT4	BIT3	BIT2	BIT1		S5	S4	S3	S2
	BIT8	BIT7	BIT6	BIT5																		
	HDI	S8	S7	S6																		
	BIT4	BIT3	BIT2	BIT1																		
	S5	S4	S3	S2																		

No.	name	Description														
13	Output terminal state	Range: (0 ~ 65535) is the decimal of output terminal state(binary). Example: 11(decimal)= 1011(binary), which means RO3,RO3 and HDO is on. <table border="1" style="margin-left: auto; margin-right: auto;"> <tr> <td>BIT6</td><td>BIT5</td><td>BIT4</td><td>BIT3</td><td>BIT2</td><td>BIT1</td><td>BIT0</td> </tr> <tr> <td>RO6</td><td>RO5</td><td>RO4</td><td>RO3</td><td>RO2</td><td>RO1</td><td>HDO</td> </tr> </table>	BIT6	BIT5	BIT4	BIT3	BIT2	BIT1	BIT0	RO6	RO5	RO4	RO3	RO2	RO1	HDO
BIT6	BIT5	BIT4	BIT3	BIT2	BIT1	BIT0										
RO6	RO5	RO4	RO3	RO2	RO1	HDO										
14	Torque compensation	Unit: %, Range:(-2000~ 2000), Example:500=50.0%; 100.0% is corresponding to rated torque at rated speed														
15	Torque at rated speed	Unit: N.m, Range: (0~ 65535), Example: 2000=2000N.m														
16	Slope frequency reference	Unit: Hz, Range: (-32767~ 32767), Example: 5000=50.00Hz														

PZD Data receiving instruction:

No.	name	Description
1	Frequency reference	Unit: %, Range:(-10000~ 10000), Example: 5000=50.00%, 100.00% is corresponding to maximum frequency P0.03.
2	Torque reference	Unit: %, Range: (-10000~ 10000) Example: 5000=50.00%, 100.00% is corresponding to the torque with upper current limit.
3	Upper limit Current reference	Unit: %, Range:(0~ 2000), Example: 500=50.0%, 100.00% is corresponding to rated current.
4	Starting pretorque compensation value	Unit: %, Range:(-2000~ 2000), Example: 500=50.0%, 100.00% is corresponding to torque at rated speed'
5	Torque upper limit frequency reference	Unit: %, Range: (-10000~ 10000),Example: 5000=50.00%, 100.00% is corresponding to maximum frequency
6	Master slave selection	Range: (0~ 65535), input data 0x55aa is corresponding to host, input data 0x66bb is slave's. Others is represent non master slave mode
7	Motor temperature reference	Range: (-2000~ 2000), Example: 500=50.0°C.

6.15 PE Group--Factory Setting

This group is the factory-set parameter group. It is prohibited for user to access.

6.16 PF Group--Motor Parameters 2

Function Code	Name	Description	Setting Range	Factory Setting
PF.00	Speed control mode 2	0:Sensorless vector control 1:Vector control With PG 2:V/F control	0~2	1
PF.01	Maximum frequency 2	10.00~400.00Hz	10.00~400.00	50.00Hz
PF.02	Motor rated speed power 2	0.4~900.0kW	0.4~900.0	Depend on model
PF.03	Motor rated speed frequency 2	0.01~400.00Hz	0.01~400.00	50.00Hz
PF.04	Motor rated speed 2	1~36000rpm	1~36000	1460rpm
PF.05	Motor rated speed voltage 2	1~480V	1~480	380V
PF.06	Motor basic speed current 2	0.1~2000.0A	0.1~2000.0	Depend on model
PF.07	Motor rated speed power factor 2	0.05~1.00	0.05~1.00	Depend on model
PF.08	Motor stator resistance 2	0.001~65.535Ω	0.001~65.535	Depend on model
PF.09	Motor rotor resistance 2	0.001~65.535Ω	0.001~65.535	Depend on model
PF.10	Motor leakage inductance 2	0.1~6553.5mH	0.1~6553.5	Depend on model
PF.11	Motor mutual inductance 2	0.1~6553.5mH	0.1~6553.5	Depend on model
PF.12	Current without load 2	0.01~655.35A	0.01~655.35	Depend on model
PF.13	Acceleration time 2	0.0~3600.0s	0.0~3600.0	20.0s

Function Code	Name	Description	Setting Range	Factory Setting
PF.14	Deceleration time 2	0.0~3600.0s	0.0~3600.0	20.0s
PF.15	Start section of acceleration S curve 2	0.1~50.0%	0.1~50.0	10.0%
PF.16	End section of acceleration S curve 2	0.1~50.0%	0.1~50.0	10.0%
PF.17	Start section of deceleration S curve 2	0.1~50.0%	0.1~50.0	10.0%
PF.18	End section of deceleration S curve 2	0.1~50.0%	0.1~50.0	10.0%
PF.19	Encoder type selection	0: Increment encoder 1: SIN/COS encoder 2: UVW encoder	0~2	0
PF.20	Encoder pulse counting 2	1~65535	1~65535	1000
PF.21	Encoder direction 2	0:forward 1:reverse	0~1	0
PF.22	Carrier frequency 2	1.0~16.0kHz	1.0~16.0	Depend on model
PF.23	ASR proportional gain K_p 2	0~100	0~100	20
PF.24	ASR integral time K_i 2	0.01~10.00s	0.01~10.00	0.50s
PF.25	Low speed detecting filter time 2	0.000~1.000s	0.000~1.000	0.000s
PF.26	ASR switching point 2	0.00Hz~PF.30	0.00~PF.30	5.00Hz

Function Code	Name	Description	Setting Range	Factory Setting
PF.27	ASR proportional gain K_p2	0~100	0~100	25
PF.28	ASR integral time K_i2	0.01~10.00s	0.01~10.00	1.0s
PF.29	High speed detecting filter time 2	0.000~1.000s	0.000~1.000	0.000s
PF.30	ASR switching point 2	PF.26~P0.03	PF.26~P0.0	10.00Hz
PF.31	ACR proportional gain P 2	0~65535	0~65535	500
PF.32	ACR integral gain I2	0~65535	0~65535	500
PF.33	Motor weak magnetic 2	1.0~2.0	1.0~2.0	1.0
PF.34	Motor Minimum weak magnetic 2	10.0~80.0%	10.0~80.0	50.0
PF.35	The proportion of weak magnetic 2	0~65535	0~65535	0
PF.36	Low-frequency threshold of restraining oscillation 2	0~10	0~10	2
PF.37	High-frequency threshold of restraining oscillation 2	0~10	0~10	0
PF.38	Maximum motor output voltage 2	PF.05~550V	PF.05~550	380V
PF.39	HF-ACR proportional gain P 2	0~65535	0~65535	1000

Function Code	Name	Description	Setting Range	Factory Setting
PF.40	HF-ACR integral gain I2	0~65535	0~65535	1000
PF.41	Slip compensation coefficient 2 of drive side	50~200	50~200	100%
PF.42	Slip compensation coefficient 2 of braking side	50~200	50~200	100%
PF.43	Torque upper limit current value 2	0.0~200	0.0~200	110%
PF.44	Motor overspeed point 2	0~200	0~200	110%
PF.45	Motor overtemperature 2	0~1	0~1	0
PF.46	Motor overtemperature threshold 2	0.0~60.0	0.0~60.0	40.0℃
PF.47	Motor overtemperature prewarning threshold 2	20.0~100.0	20.0~100.0	90%
PF.48	Motor temperature compensation enable 2	0~1	0~1	0
PF.49	Motor temperature compensation initial threshold 2	0.0~60.0	0.0~60.0	40.0℃
PF.50	Motor temperature compensation coefficient 2	0.0~200.0	0.0~200.0	100
PF.51	Reserved	0~65535	0~65535	0
PF.52	Reserved	0~65535	0~65535	0
PF.53	Motor type 2	0~1	0~1	0

Function Code	Name	Description	Setting Range	Factory Setting
PF.54	Magnetic pole initial position 2	0.00~360.00	0.00~360.00	0
PF.55	Magnetic pole position amplitude gain 2	0.50~1.50	0.50~1.50	1
PF.56	C phase magnetic pole position bias 2	0~9999	0~9999	433
PF.57	D phase magnetic pole position bias 2	0~9999	0~9999	433

6.17 PP Group--Motor Parameters 3

Function Code	Name	Description	Setting Range	Factory Setting
PP.00	Speed control mode 3	0:Sensorless vector control 1:Vector control With PG 2:V/F control	0~2	1
PP.01	Maximum frequency 3	10.00~400.00Hz	10.00~400.00	50.00Hz
PP.02	Motor rated speed power 3	0.4~900.0kW	0.4~900.0	Depend on model
PP.03	Motor rated speed frequency 3	0.01~400.00Hz	0.01~400.00	50.00Hz
PP.04	Motor rated speed 3	1~36000rpm	1~36000	1460rpm
PP.05	Motor rated speed voltage 3	1~480V	1~480	380V
PP.06	Motor basic speed current 3	0.1~2000.0A	0.1~2000.0	Depend on model
PP.07	Motor rated speed power factor 3	0.05~1.00	0.05~1.00	Depend on model

Function Code	Name	Description	Setting Range	Factory Setting
PP.08	Motor stator resistance 3	0.001~65.535Ω	0.001~65.535	Depend on model
PP.09	Motor rotor resistance 3	0.001~65.535Ω	0.001~65.535	Depend on model
PP.10	Motor leakage inductance 3	0.1~6553.5mH	0.1~6553.5	Depend on model
PP.11	Motor mutual inductance 3	0.1~6553.5mH	0.1~6553.5	Depend on model
PP.12	Current without load 3	0.01~655.35A	0.01~655.35	Depend on model
PP.13	Acceleration time 3	0.0~3600.0s	0.0~3600.0	20.0s
PP.14	Deceleration time 3	0.0~3600.0s	0.0~3600.0	20.0s
PP.15	Start section of acceleration S curve 3	0.1~50.0%	0.1~50.0	10.0%
PP.16	End section of acceleration S curve 3	0.1~50.0%	0.1~50.0	10.0%
PP.17	Start section of deceleration S curve 3	0.1~50.0%	0.1~50.0	10.0%
PP.18	End section of deceleration S curve 3	0.1~50.0%	0.1~50.0	10.0%
PP.19	Encoder type selection	0: Increment encoder 1: SIN/COS encoder 2: UVW encoder	0~2	0
PP.20	Encoder pulse counting 3	1~65535	1~65535	1000
PP.21	Encoder direction 3	0:forward 1:reverse	0~1	0

Function Code	Name	Description	Setting Range	Factory Setting
PP.22	Carrier frequency 3	1.0~16.0kHz	1.0~16.0	Depend on model
PP.23	ASR proportional gain K_p 3	0~100	0~100	20
PP.24	ASR integral time K_i 3	0.01~10.00s	0.01~10.00	0.50s
PP.25	Low speed detecting filter time 3	0.000~1.000s	0.000~1.000	0.000s
PP.26	ASR switching point 3	0.00Hz~PP.30	0.00~PF.30	5.00Hz
PP.27	ASR proportional gain K_p 3	0~100	0~100	25
PP.28	ASR integral time K_i 3	0.01~10.00s	0.01~10.00	1.0s
PP.29	High speed detecting filter time 3	0.000~1.000s	0.000~1.000	0.000s
PP.30	ASR switching point 3	PP.26~P0.03	PP.26~P0.0	10.00Hz
PP.31	ACR proportional gain P 3	0~65535	0~65535	500
PP.32	ACR integral gain I3	0~65535	0~65535	500
PP.33	Motor weak magnetic 3	1.0~2.0	1.0~2.0	1.0
PP.34	Motor Minimum weak magnetic 3	10.0~80.0%	10.0~80.0	50.0
PP.35	The proportion of weak magnetic 3	0~65535	0~65535	0
PP.36	Low-frequency threshold of restraining	0~10	0~10	2

Function Code	Name	Description	Setting Range	Factory Setting
	oscillation 3			
PP.37	High-frequency threshold of restraining oscillation 3	0~10	0~10	0
PP.38	Maximum motor output voltage 1	PP.05~550V	PP.05~550	380V
PP.39	HF-ACR proportional gain P3	0~65535	0~65535	1000
PP.40	HF-ACR integral gain I3	0~65535	0~65535	1000
PP.41	Slip compensation coefficient 3 of drive side	50~200	50~200	100%
PP.42	Slip compensation coefficient 3 of braking side	50~200	50~200	100%
PP.43	Torque upper limit current value 3	0.0~200	0.0~200	110%
PP.44	Motor overspeed point 3	0~200	0~200	110%
PP.45	Motor overtemperature 3	0~1	0~1	0
PP.46	Motor overtemperature threshold 3	0.0~60.0	0.0~60.0	40.0℃
PP.47	Motor overtemperature prewarning threshold 3	20.0~100.0	20.0~100.0	90%

Function Code	Name	Description	Setting Range	Factory Setting
PP.48	Motor temperature compensation enable 3	0~1	0~1	0
PP.49	Motor temperature compensation initial threshold 3	0.0~60.0	0.0~60.0	40.0℃
PP.50	Motor temperature compensation coefficient 3	0.0~200.0	0.0~200.0	100
PP.51	Reserved	0~65535	0~65535	0
PP.52	Reserved	0~65535	0~65535	0
PP.53	Motor type 3	0~1	0~1	0
PP.54	Magnetic pole initial position 3	0.00~360.00	0.00~360.00	0
PP.55	Magnetic pole position amplitude gain 3	0.50~1.50	0.50~1.50	1
PP.56	C phase magnetic pole position bias 3	0~9999	0~9999	433
PP.57	D phase magnetic pole position bias 3	0~9999	0~9999	433

7. DESCRIPTION OF CHV190'S EXTENSION CARD

7.1 Description of I/O Extension Card

7.1.1 Description of I/O extension card terminal and jumper

(1) Terminals

Terminal	Description
S7~S10	ON-OFF signal input, optical coupling with PW and COM Input voltage range:9~30V Input impedance:3.3KΩ
COM	Common ground terminal for +24V or exterior power
GND	Common ground terminal of +10V
Y2	Open collector output terminal, the corresponding common ground output terminal is CME Exterior voltage range:0~24V Output current range:0~50mA
CME2	Open collector output common terminal
AO2	Analog quantity output terminal Output range:0~10V/0~20mA(select voltage or current output can be switched by J2)
RO3A,RO3B,RO3C	Relay output:RO3A common,RO3B NC,RO3C NO Contact capacity:AC250V/3A,DC30V/1A
RS485+,RS485-	RS485 Communication
CANH,CANL	CAN communication ports(reserved)
PT100,GND	Motor temperature detection input, support PT100 and PT1000

Notice: GND must isolate from COM.

(2) Jumper

Jumper	Description
J1	1 connect to 2 means paralleling a 120Ω matching resistance for CAN control output terminal, 2 and 3 are be hanged in the air.
J2	Switch between 0~10V coltage input or 0~20mA current input 1(V)connect to 2(GND)means voltage input: 2(GND) connect to 3(I)means current inout.

Jumper	Description
S1	Selection of RS485 communication terminal organ setting. ON: enable terminal organ; OFF: forbidden terminal organ. When the RS485 port is at the end of RS485 communication network cable, which need enable terminal organ.

7.1.2 Description of dimension and terminal compositor

(1) Dimension of I/O extension card and sketch map for CHV190

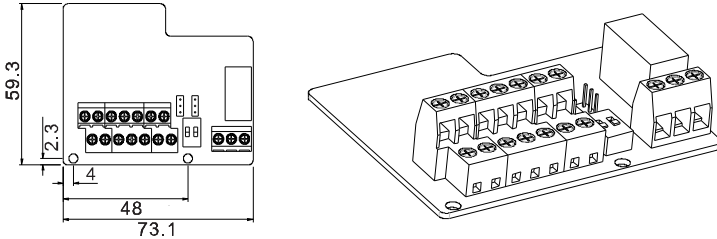
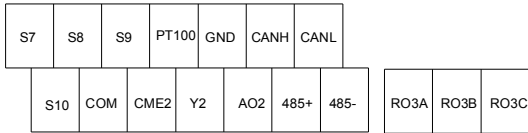

Figure 7.1 Dimension of I/O extension card

(2) Sketch map of terminal compositor



7.1.3 Installation of I/O extension card for CHV190

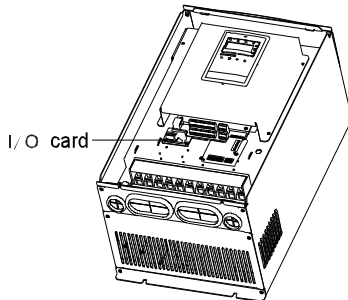

Figure 7.2 Installation of I/O extension card and PG card

7.2 Description of Asynchronous PG Card

7.2.1 Model and specifications

7.2.1.1 Model description and technical specifications

The technical features of the model of PG card for CHV190 inverters are as follow:

Terminal	Technical features
12V,COM1	Encoder power supply, maximum output current is 300mA
TERA+,TERA-, TERB+,TERB-	Encoder signal input access Voltage range: 12~15V Response speed: 0~80kHz
TER-OA TER-OB	Frequency output: 0~80kHz Output impedance: 30Ω Frequency division range: 1~256

7.2.1.2 Dimensions and installation

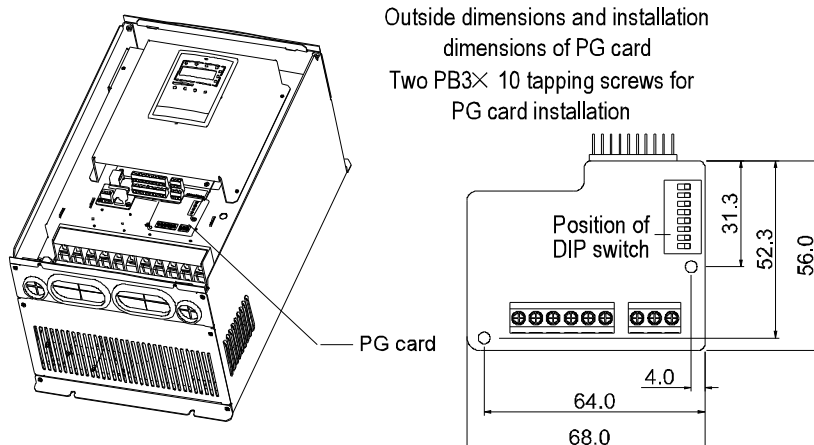

Figure 7.3 Installation and Dimensions of PG Card

NOTICE: The contact pin of PG card is inserted into the below connector with control board CN9.

7.2.2 Operating Instructions of asynchronous motor PG card

7.2.2.1 Functions

If the user requires PG vector control, need to select PG card. The function of the PG card includes processing circuits for two channels of orthogonal coder signals, capable of receiving signals from differential output, open-circuit collector output and push-pull output encoders, Coder power supply (+12V output, adjustable through the potentiometer on the PG card). In addition, it can output in frequency-division the inputted encoder signals (output are two channels of orthogonal signals). The user can make selection according to actual situations.

7.2.2.2 Description of terminals and DIP Switch

The PG card has nine wiring terminals, as shown in Figure 7.4.

+12V	COM1	TERA+	TERA-	TERB+	TERB-	TER-OA	TER-OB	COM1
------	------	-------	-------	-------	-------	--------	--------	------

Figure 7.4 User wiring terminals of PG Card.

Where, +12V and COM1 are working voltage output for the coder; TERA+, TERA-, TERB+, and TERB- are signal input terminals for the coder; TER-OA, TER-OB, and COM1 are output terminals for frequency-division signals; PE is the wiring terminal for shielding cable (PE inside the PG card is not connected to the ground, and the user can connect it to the ground during use).

The frequency division factor is determined by the DIP switch on the card. The DIP switch consists of 8 bits. When the binary digits are displayed by DIP switch pluses 1, the relative value is frequency division factor. The bit marked as "1" on the DIP switch is the lower binary bit, while "8" is the higher binary bit. When the DIP switch is switched to ON, the bit is valid, indicating "1"; otherwise, it indicates "0".

Frequency division factors are shown in the table below:

Decimal digit	Binary digit	Frequency division factor
0	00000000	1
1	00000001	2
2	00000010	3
...
m	...	m+1
255	11111111	256

7.2.2.3 Wiring diagram

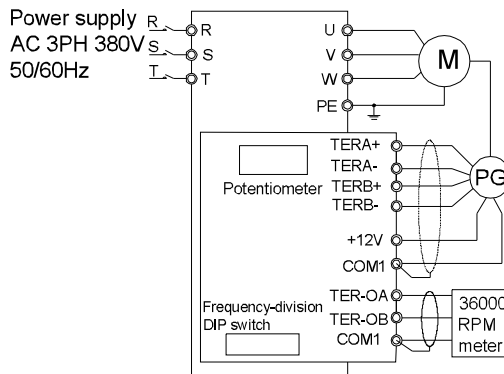

Figure 7.5 PG card wiring diagram

7.2.2.4 Notice

1. The signal line of PG card should be separated from the power line. Parallel

wiring is forbidden.

2. To prevent coder signals from disturbance, please select a shielded cable as the signal line of PG card.

3. The shielding layer of shielded cable of PG card should be grounded (such as terminal PE of the inverter), and furthermore, only one end is grounded, to prevent signal from disturbance.

4. If the frequency-division output of PG card is connected to user power supply, the voltage should be less than 24V; otherwise, the PG card may be damaged.

7.2.3 Application connection

(1) Wiring diagram of differential output coder

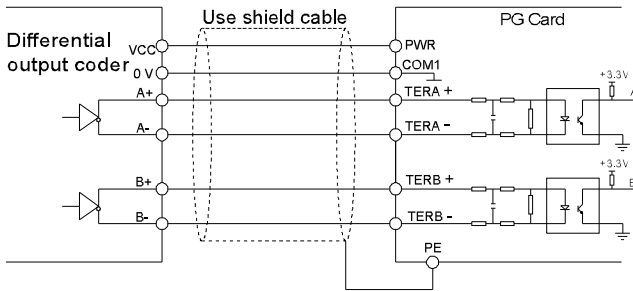

Figure 7.6 Wiring diagram of differential output coder.

(2) Wiring diagram of open collector output coder

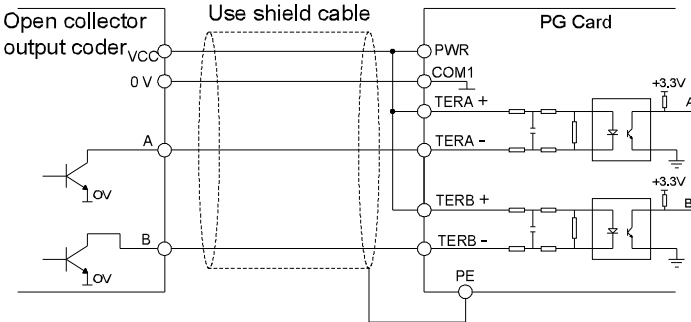

Figure 7.7 Wiring diagram of open collector output coder

(3) Wiring Diagram of Push-pull Output Coder

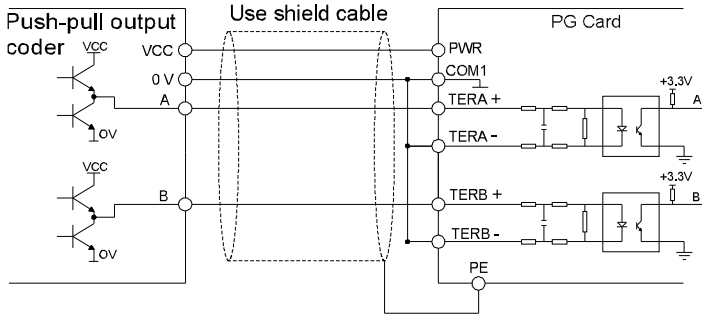

Figure 7-8 Wiring diagram of push-pull output coder.

(4)Wiring diagram of PG card frequency-division output

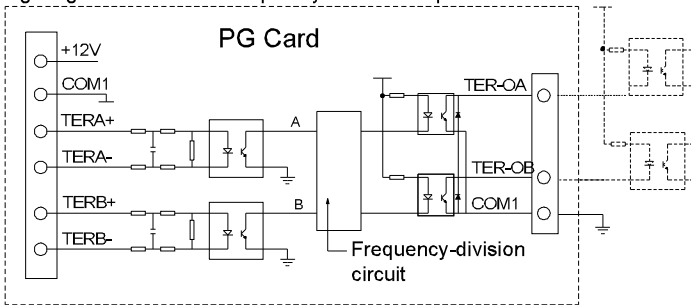

Figure 7.9 Wiring diagram of PG Card frequency-division output

7.3 Description of Synchronous PG Card

7.3.1 Model and specifications

The model of PG card for CHV190 inverters is ASY-2010-T. The technical features are as follow:

Terminal	Technical features
+5V	Encoder power, the maximum output current is 130mA
The encoder types	Support SIN/COS and UVW encoder, The signal is differential input.
Respond speed	0~80kHz
TER-OA,TER-OB	Output frequency: 0~80kHz Output impedance: 30Ω Frequency division range: 1~256 Voltage output range: 5 ~ 30V

7.3.2 Dimensions and installation

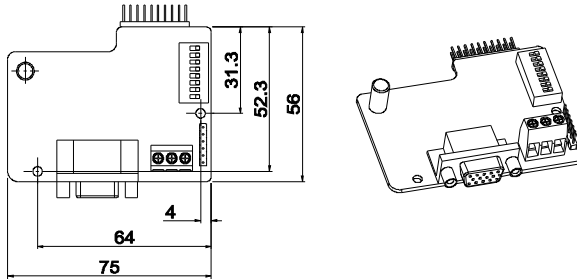

Figure 7.10 Dimension and installation of synchronous PG Card.

Notice: The position and installation of synchronous PG card is the same as the asynchronous PG card, but there are two lines pins, the asynchronous PG card has only one line pin.

The PG card of asynchronous motor is the same as all of CHV series inverters, but the PG card of synchronous motor is only used to CHV190 inverter. The PG card is compatible with SIN/COS and UVW encoder, the output voltage is +5V, and the precision is $\pm 5\%$. At the same time, its output frequency division to encoder is valid.

7.3.3 Description of terminals and DIP switch

The PG card has one signal port and three user ports shown as in Figure 7.11.

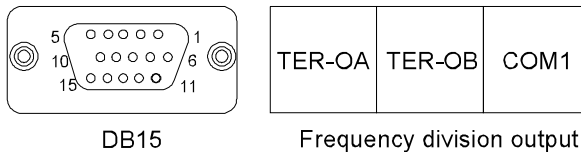

Figure 7.11 The PG Card port and terminals.

TER-OA, TER-OB and COM1 are the signal frequency division output terminals.

NOTICE: The PE terminal PG Card has not connected to earth; user must connect the card to earth.

DB15 is the port of the encoder input signal. The order of the ports signal is as follow:

Port	SIN/COS	UVW
8	A	A
3	A-	A-
9	B	B
4	B-	B-
15	R	Z
14	R-	Z-
6	C	U

Port	SIN/COS	UVW
1	C-	U-
7	D	V
2	D-	V-
12	5V	5V
13	0V	0V
10	Empty	W
5	Empty	W-
11	Empty	Empty

Use DB15 connect synchronous PG card to SIN/COS or UVW encoder.

The frequency division factor is determined by the DIP switch on the card. The DIP switch consists of 8 bits. The binary digits plus 1 is frequency division factor. The bit marked as “1” on the DIP switch is the lower binary bit, while “8” is the higher binary bit. When the DIP switch is switched to ON, the bit is valid, indicating “1”; otherwise, it indicates “0”.

Frequency division factors are shown in the table as below:

Decimal digit	Binary digit	Frequency division factor
0	00000000	1
1	00000001	2
2	00000010	3
...
m	...	m+1
255	11111111	256

7.4 Description of Modbus Communication Card

7.4.1 Model

The model of CHV190's Modbus communication card is PN000TXWX, and it is compatible with CHV's extension card. This card supports RS232 and RS485.

7.4.2 Installation

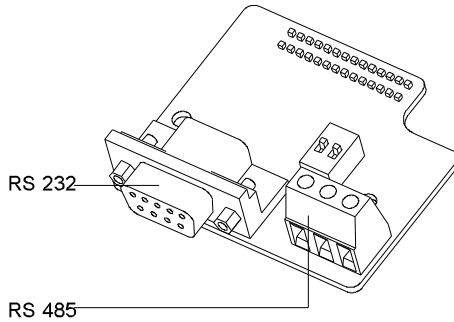

Figure 7.12 Modbus communication card

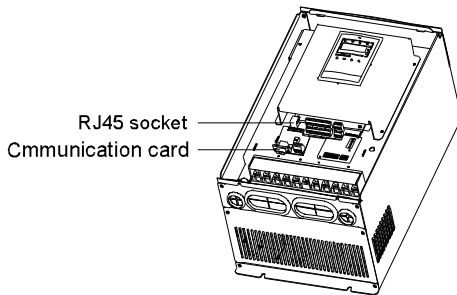

Figure 7.13 Installation of communication card

7.4.3 Application of Modbus communication card

The Modbus communication card achieve communication between CHV 190 inverters and host (PLC, industrial PC), it is necessary to choose this communication card. The electric parameters can meet relative international standards and can implement smooth communications between CHV inverter and host.

7.4.4 Terminals

The communication card has two groups of terminals, as shown in Figure 7.14.

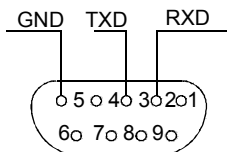

Figure 7.14 D9: Bus-connector terminal

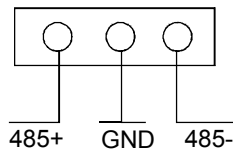

Figure 7.15 RS485 terminal

7.4.5 Notice:

1. Please install this card when the inverter is completely powered off.
2. Please make sure the communication card and control board are well connected, and use screws to fix the communication card.
4. To prevent communication signals from external disturbance, please choose twisted

pairs as communication cable, and try to avoid parallel wiring with the drive power.

5. Suggest using the shielded cable for RS232 communication.

7.5 Description of Profibus Communication Card

7.5.1 Introduction

7.5.1.1 Profibus standard

(1) Profibus is an open international fieldbus standard. The standard allows data exchange among various types of automation components. It is widely used in manufacturing automation, process industrial automation and in other areas automation such as buildings, transportation and electric power etc.

(2) Profibus is composed of three compatible components, Profibus-DP (Decentralized Periphery, distributed peripherals), Profibus-PA (Process Automation), Profibus-FMS (Fieldbus Message Specification, Fieldbus Message Specification). It is periodically exchange data with the inverter when using master-slave function. PRNV Profibus-DP adapter module only supports Profibus-DP protocol.

(3) The physical transmission medium is twisted-pair (in line with RS485 standard), two-wire cable or fiber optic cable. Baud rate is from 9.6Kbit/s to 12Mbit/s. The maximum length of cable is between 100 m and 1200 m, specific length depending on the selected transmission rate (see the technical data chapter). Up to 31 nodes can be connected to the same Profibus network when repeaters aren't used. But, if use repeaters, up to 127 nodes can be connected to the same Profibus network segment (including repeaters and master stations).

(4) In the process of Profibus communication, token assign among hosts and master-slave transmission among master-slave stations, which support single-host or multi-host system. Host stations (PLC) select nodes to respond to the host instruction. Cyclic host-from user data transmission and non-cyclic host-host station can also send commands to multiple nodes in the form of broadcast. In this case, the nodes do not need to send feedback signals to the host. In the Profibus network, communication between nodes can not be allowed.

(5) Profibus protocol is described in detail in EN 50170 standard. To obtain more information about Profibus, please refer to the EN 50170 standard.

7.5.1.2 Product naming convention

Fieldbus adapter naming rules, the product model:

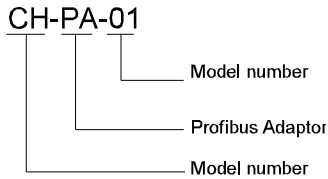

Figure 7.16 Profibus-DP naming convention

7.5.1.3 The adapter module of CH-PA01 Profibus-DP

CH-PA01 Profibus-DP Adapter module is an optional device to inverter which can connect inverter to Profibus network. In Profibus network, inverter is a subsidiary device. Using CH-PA01 Profibus-DP adapter module can achieve function as below.

- Send control commands to inverter (start, stop, fault reset, etc.).
- Send speed or torque reference to inverter.
- Read out status and actual values of inverter.
- Modify the inverter parameter.

Please refer to Pd group parameter to know function supported by inverter. INVT Inverter connected to the Profibus bus structure is shown in Figure 7.17:

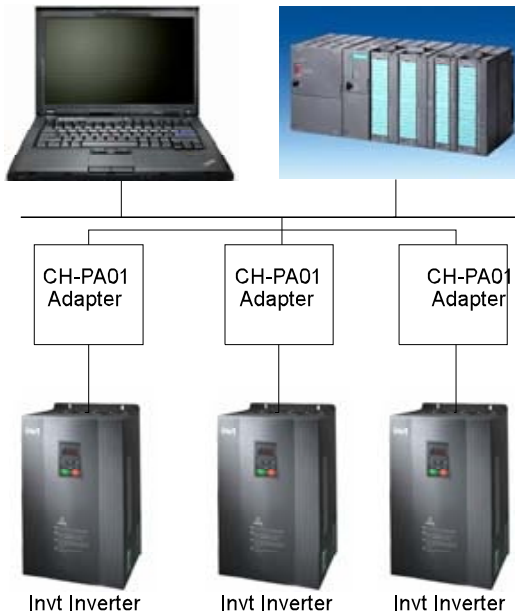

Figure 7.17 Profibus communication structure diagram

7.5.1.4 CH-PA01 Profibus-DP Adapter outline structure

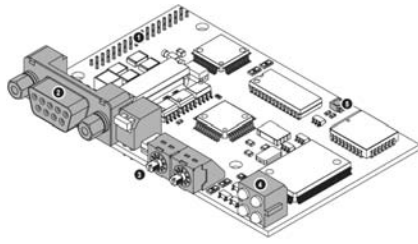

Figure 7.18 CH-PA01 Adapter Module Outline diagram

- | | |
|-------------------------------|--|
| 1. Interface to control panel | 3. Rotative switch of node address selection |
| 2. Bus connector | 4. Status display LEDs |

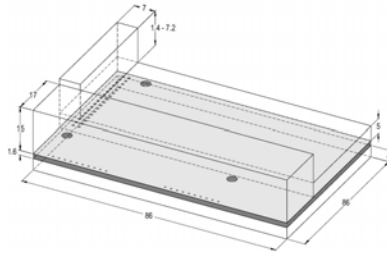

Figure 7.19 CH-PA01 adapter External Dimensions (Unit: mm)

7.5.1.5 CH-PA01 related product information

CH-PA01 adapter is compatible with the following products:

- CH-PA01 is compatible with CHV190 series inverter and other devices supporting Profibus card.
- All host stations support Profibus-DP protocol.

The list of deliverables

The package of CH-PA01 Profibus-DP adapter module includes:

- Profibus-DP adapter module, model number is CH-PA01
- Three fixed connection column
- One manual
- One CD-ROM (GSD file)

If you find some missing, please contact with SHENZHEN INVT ELECTRIC CO., LTD or suppliers.

Notice: We will not remind for the reasonable product upgrades.

7.5.2 Adapter installation

7.5.2.1 Adapter machinery installation

Installation environment

- Ambient temperature: 0 °C ~ +40 °C
- Relative humidity: 5% ~ 95%
- Other climate conditions: non-condensing, freezing, rain, snow, hail, etc., solar radiation below 700W/m², air pressure 70~106kPa
- Salt spray and corrosive gases: Pollution Level 2
- Dust and solid particles content: Pollution Level 2
- Vibration and shock: 5.9m/s² (0.6g) when sinusoidal vibration is 9~ 200Hz.

Installation steps:

- Fix three copper columns to H5, H6 and H7 on the panel.
- Insert module into socket J20 on the control board carefully, then fixed to the connecting column.
- Set bus termination switch of module to the desired location.

Notice:

Be sure that power is cut off and wait at least 3 minutes to ensure the completion of capacitor discharge. Cut off dangerous voltages which is external control circuit to unit input and output terminals.

Electronic components on the CH-PA01 adapter module circuit board are sensitive to electrostatic discharge. Do not touch circuit boards with hands. Please wear a grounded wrist strap when you need dealing with circuit boards.

7.5.2.2 Adapter electrical Installation

7.5.2.2.1 Node selection

Node address is the only address that devices have on the Profibus bus, and it is decided by rotative switch of node address selection. The range of node address number is from 00~99. The left switch represents first number and the right switch represents second number.

Node Address = 10*first number + 1*second number

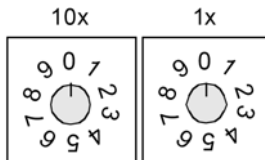

Figure 7.20 Node selection

7.5.2.2.2 Bus terminators

Each head and tail has a bus terminator to ensure that error doesn't occur in the operation. DIP switches on CH-PA01 are connected to the bus terminator which can prevent signal reflection. If the module is the first or the last one in the network, the bus terminator must

be set as ON. If D-sub connector is built in the Profibus, CH-PA01 terminators must be disconnected.

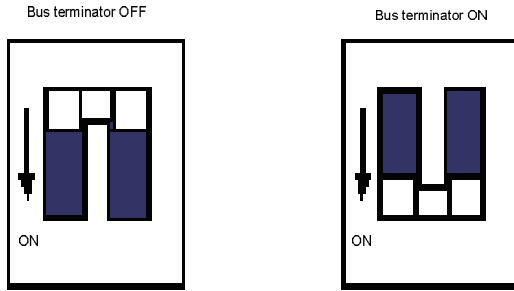

Figure 7.21 Bus terminators

7.5.2.3 CH-PA01 adapter bus network connection

Bus communication interface

Shielded twisted-pair copper wire (in line with RS485 standard) transmission is the most common way in Profibus transmission.

Transmission basic characteristics:

- Network topology: linear bus, terminal resistors at both ends.
- Transmission rate: 9.6K bit / s ~ 12M bit / s
- Medium: shielded twisted-pair cable or canceling shield, depending on environmental conditions (EMC).
- Sites number: 32 stations per section (without repeater), up to 127 stations (with repeater).
- Terminal: 9 pin D-type port, diagram of connector pin as shown in table 7-1:

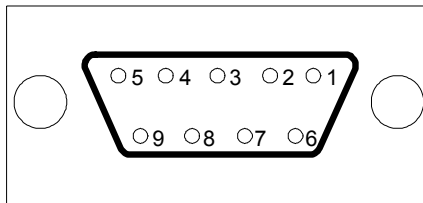

Figure 7.22 Connector pin sequencing

Table 7.1 Connector pin allocation

Connector pin		Description
1	-	unused
2	-	unused
3	B-Line	Data positive (twisted pair 1)

Connector pin		Description
4	RTS	Sending request
5	GND_BUS	Isolated ground
6	+5V BUS	Isolated 5V DC power supply
7	-	unused
8	A-Line	Data negative (twisted pair 1)
9	-	Unused
Housing	SHLD	Profibus shielded cable

+5 V and GND_BUS are used for bus terminators. Some devices, such as optical transceivers (RS485), may need to obtain an external power supply from these pins.

In some devices, use the RTS to determine sending direction. In normal applications, only use A-Line, B-Line and shielded layer.

Recommend using standard DB9 port produced by SIEMENS Company; please refer to wiring standard if communication baud rate is greater than 187.5kbps.



Figure 7.23 Standard Profibus port

Repeater

Up to 32 stations can be connected to each segment (master station or subsidiary stations), the repeater have to be used when stations is more than 32. Repeaters in series are generally no more than 3. (Notice: there is no repeater station address)

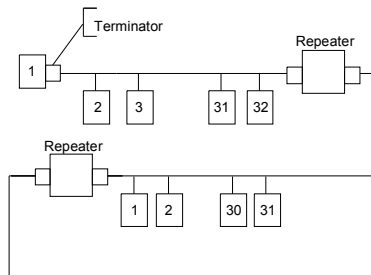

Figure 7.24 Up to 32 stations on each section

7.5.2.4 Transmission rate and maximum distance

Maximum length of cable depends on the transmission rate.

Table 7.2 shows the relationship between transmission rate and distance.

Table 7.2 Bus transmission distance

Transfer rate (kbps)	A-wire (m)	B-wire (m)
9.6	1200	1200
19.2	1200	1200
93.75	1200	1200
187.5	1000	600
500	400	200
1500	200	-----
12000	100	-----

Table 7.3 Transmission line parameters

Transfer rate (kbps)	A-wire (m)	B-wire (m)
Impedance (Ω)	135~165	100~130
Capacitance per unit length(pF/m)	< 30	< 60
Loop Resistance (Ω /km)	110	-----
Core wire diameter (mm)	0.64	> 0.53
Line-core cross-section (mm^2)	> 0.34	> 0.22

Besides shielding twisted-pair copper wires, Profibus can also use optical fiber for transmission in an electromagnetic interference environment to increase the high-speed transmission distance there are two kinds of fiber optical conductors, one is low-cost plastic fiber conductor, used distance is less than 50 meters, the other is glass fiber conductor, and used distance is less than 1 km.

7.5.2.5 Profibus connection diagram

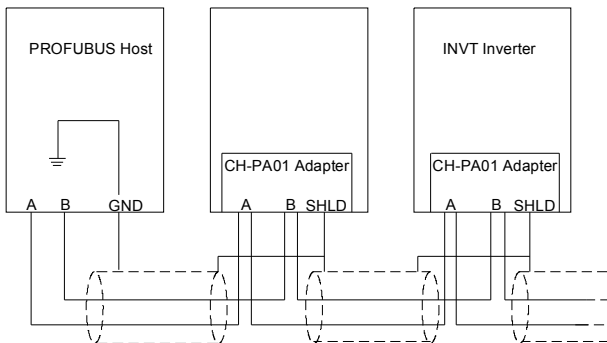

Figure7.24 Standard profibus cable wiring diagram

Above is "terminal" wiring diagram. Cable is a standard Profibus cable consisting of a twisted pair and shielding layer. The shielded layer of Profibus cable on all nodes is directly grounded. Users can choose the best way grounding according to the situation.

Wiring precautions

Make sure that signal lines do not twist when connecting all stations. Shielded cable should be used when system runs under high electromagnetic interface environment, which can improve electromagnetic compatibility (EMC).

If using shielded braided wire and shielding foil, both ends should be connected to ground. Using shielding area should be large enough to maintain a good conductivity. And data lines must be separated from high-voltage.

Stub line segment should not be used when transmission rate more than 500K bit/s, The plug is available on the market which connects directly to data input and output cable. Bus plug connection can be on or off at any time without interruption of data communications of other station.

7.5.3 System configuration

7.5.3.1 System Configuration

Host station and inverter should be configured so that the host station can communicate with the module after correctly installing CH-PA01 Profibus-DP Adapter module.

Each Profibus subsidiary station on the Profibus bus need to have "device description document" named GSD file which used to describe the characteristics of Profibus-DP devices. The software we provided for the user includes inverter related GSD files (device data files) information, users can obtain type definition file (GSD) of host machines from local INVT agent.

Table 7.4 CH-PA01 configuration parameters

Parameter Number	Parameter Name	optional setting	Factory setting
0	Module type	Reading only	Profibus-DP
1	Node address	0~99	2
2	PZD3	0~65535	0
3	PZD4	Ibid	0
...	Ibid	0
9	PZD12	Ibid	0

7.5.3.2 Module type

This parameter shows communication module type detected by inverter; users can not adjust this parameter. If this parameter is not defined, communication between the modules and inverter can not be established.

7.5.3.3 Node address

In Profibus network, each device corresponds to a unique node address, using node address selection switch to define node address (switch isn't at 0) and the parameter is only used to display the node address. If node address selection switch is 0, this parameter can define node address.

7.5.3.4 GSD file

In Profibus network, each Profibus subsidiary station needs GSD file "device description document" which used to describe the characteristics of Profibus-DP devices. GSD file contains all defined parameters, including baud rate, information length, amount of input/output data, meaning of diagnostic data.

A CD-ROM will be offered in which contains GSD file (extension name is .gsd) for fieldbus adapter. Users can copy GSD file to relevant subdirectory of configuration tools, please refer to relevant system configuration software instructions to know specific operations and Profibus system configuration.

7.5.4 Profibus-DP communication

7.5.4.1 Profibus-DP

Profibus-DP is a distributed I/O system, which enables host machine to use a large number of peripheral modules and field devices. Data transmission shows cycle: host machine read input information from subsidiary machine then give feedback signal. CH-PA01 adapter module supports Profibus-DP protocol.

Service access point

Profibus-DP has access to Profibus data link layer (Layer 2) services through service access point SAP. Every independent SAP has clearly defined function. Please refer to relevant Profibus user manual to know more about service access point information. PROFIDRIVE-Variable speed drive adopts Profibus model or EN50170 standards (Profibus protocol).

7.5.4.2 Profibus-DP information frame data structures

Profibus-DP bus mode allows rapid data exchange between host station and inverter. Adopting master-slave mode dealing with inverter access, inverter is always subsidiary station, and each has definite address. Profibus periodic transmission messages use 16 words (16 bit) transmission, the structure shown in figure 7.26.

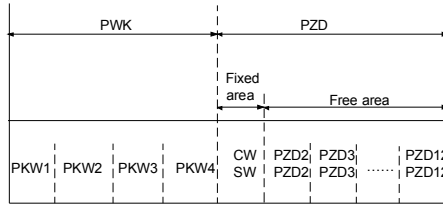

Figure 7.25 Profibus-DP message structure

Parameters area:

PKW1-Parameter identification

PKW2-array index number

PKW3-parameter value 1

PKW4-parameter value 2

Process data:

CW-Control word (from master to slave, see Table 7.5)

SW-status word (from slave to host, see Table 7.7)

PZD-process data (decided by users) (From master to slave output **【given value】** , from slave to master input **【actual value】**)

PZD area (process data area)

PZD area of communication message is designed for control and monitor inverter. PZD from host and slave station is addressed in high priority, the priority of dealing with PZD is superior to that of PKW, and always send current valid date from interface.

Control word (CW) and status word (SW)

Control word (CW) is a basic method of fieldbus system controlling inverter. It is sent by the fieldbus master station to inverter and the adapter module act as gateway. Inverter responds according to the control word and give feedbacks to host machine through status word (SW).

Contents of control word and status word is shown in table 7.5 and table 7.7 respectively.

Please refer to inverter manual to know bit code.

Given value

Inverter can receive control information by several ways, these channels include: analog and digital input terminals, inverter control board and module communication (such as RS485, CH-PA01 adapter modules). In order to use Profibus control inverter, the communication module must be set to be inverter controller.

Contents of setting value are shown in Table 7.6.

Actual value

Actual value is a 16-bit word, which contains converter operation information. Monitoring capabilities are defined by inverter parameter. The integer scaling of actual value is sent to host machine depending on selected function, please refer to inverter manual.

Contents of actual values are shown in Table 7.8.

Notice: inverter always check the control word (CW) and bytes of given value.

Mission message (From host station to inverter)

Control word (CW)

The first word of PZD is control word (CW) of inverter, due to different control word (CW) of PWM rectifier regenerative part and inverter part Illustration is depart in next two tables.

Table 7.5 Control word (CW) of CHV190

Bit	Name	Value	Status/Description
00	HEARTBEAT REF	1	Heartbeat enable
		0	Heartbeat banned
01	EXTERNAL RESET	1	Fault reset, if the fault still exists
		0	Continue running normally
02	FORWARD COMMAND	1	Forward command
		0	Deceleration stop
03	REVERSE COMMAND	1	Reverse command
		0	Deceleration stop
04	EXCITING COMMAND	1	Excitation enable
		0	Excitation unable
05	TORQUE CONTROL SELECTION	1	Torque control enable
		0	Torque control banned
06	EXTERNAL SAFE SWITCH	1	External safe switching enable
		0	Coast to stop
07	QUICK STOP COMMAND	1	Continue running normally
		0	Emergency disconnect, fast stop deceleration mode
08	GROUP B SELECTION	1	Motor B switching
		0	Continue running normally
09	WRITE ENABLE	1	Write enable (mainly PKW1-PKW4)
		0	Write unable
10 To 15	Reserved	1	Reserved
		0	Reserved

Setting value (REF):

From 2nd word to 12th of PZD task message is the main setting value REF, main frequency setting value is offered by main setting signal source. As PWM rectifier feedback part doesn't have main frequency setting part, corresponding settings belong to reserved part, the following table shows inverter part settings for CHV 190.

Table 7.6 CHV190 settings

Bit	Name	From host to slave
PZD2	SPEED REF	Decided by host
PZD3	TENSION REF	Decided by host
PZD4	CURRENT LIMIT CLAMP	Decided by host
PZD5~ PZD12	Reserved	Reserved

Response message (From inverter to main station)

Status word (SW):

The first word of PZD response message is status word (SW) of inverter, the definition of status word is as follows:

Table 7.7 Status Word (SW) of CHV190

Bit	Name	Value	Status/Description
00	HEARTBEAT FEEDBACK	1	Heartbeat feedback
		0	No heartbeat feedback
01	FAULT	1	Fault
		0	No fault
02	DC VOLTAGE ESTABLISH	1	DC voltage establish
		0	DC voltage unestablish
03	GROUP B FEEDBACK	1	Motor B feedback
		0	Motor B no feedback
04	QUICK STOP FEEDBACK	1	Stop invalid
		0	Emergency stop in fastest speed enable
05	DRIVE CURRENT LIMIT FEEDBACK	1	Drive current limit feedback enable
		0	Drive current limit feedback unable
06	DRIVE FLUX ENABLED	1	Drive flux enabled
		0	Drive flux disabled
07	RUNNING FORWARD	1	Running forward

Bit	Name	Value	Status/Description
		0	No running forward
08	RUNNING REVERSE	1	Running reverse
		0	No running reverse
09	MOTOR TEMPERATURE	1	Motor temperature alarm
		0	No motor temperature alarm
10	FLUX IN EXCITING	1	Flux in exciting
		0	Flux establish
10 To 15	Reserved		Reserved

Actual value (ACT):

From 2nd word to 12th of PZD task message is main setting value ACT, main frequency setting value is offered by main setting signal source.

Table 7.8 Actual value of CHV190

Bit	Name	From slave to host
PZD2	FAULT CODE	Fault code:0~N
PZD3	SPEED FEEDBACK	Speed feedback actual value
PZD4	PG POS COUNTER	PG Card position
PZD5	DRIVE TORQUE FEEDBACK	Torque actual value
PZD6	Motor Running Freq.	Actual value of motor running freq.
PZD7	DRIVE CURRENT FEEDBACK	Drive current feedback actual value
PZD8	DRIVE VOLTAGE FEEDBACK	Drive voltage feedback actual value
PZD9- PZD12	Reserved	Reserved

PKW area (parameter identification marks PKW 1-value area)

PKW area describes treatment of parameter identification interface, PKW interface is a mechanism which determine parameters transmission between two communication partners, such as reading and writing parameter values.

Structure of PKW area:

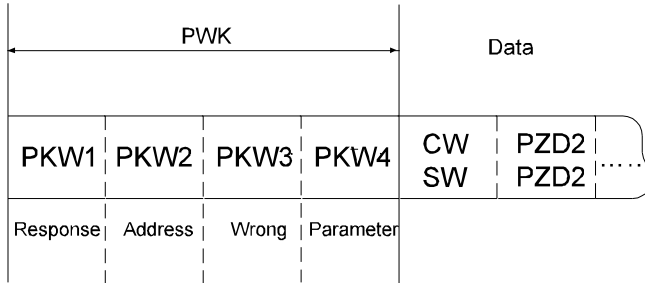

Figure 7.26 Parameter identification zone

In the process of periodic Profibus-DP communication, PKW area is composed of four words (16 bit), each word is defined as follows:

The first word

The first word PKW1 (16 bit)		
Bit 15~00	Task or response identification marks	0~7

The second word

The second word PKW2 (16 bit)		
Bit 15~00	Basic parameters address	0~247

The third word

The third word PKW3 (16 bit)		
Bit 15~00	Parameter value (high word) or return error code value	00

The fourth word

The fourth word PKW4 (16 bit)		
Bit 15~00	Parameter value (low word)	0~65535

Notice: If main station requests one parameter value, the value of PKW3 and PKW4 is no longer valid.

Task requests and responses

When passing data to slave machine, host machine use request label while slave machine use response label to positive or negative confirmation. Table 5.5 and Table 5.6 list the request/response functional.

The definition of task logo PKW1 is as follows:

Table 7.9 Definition of task logo PKW1

Request label (From host to slave)		Response label	
Request	Function	Positive confirmation	Negative confirmation
0	No task	0	—

Request label (From host to slave)		Response label	
1	Request parameter value	1,2	3
2	Modification parameter value (one word) [only change RAM]	1	3 or 4
3	Modification parameter value (double word) [only change RAM]	2	3 or 4
4	Modification parameter value (one word) [RAM and EEPROM are modified]	1	3 or 4
5	Modification parameter value (double word) [RAM and EEPROM are modified]	2	3 or 4

Request label

"2"-modification parameter value (one word) [only change RAM],

"3"-modification parameter value (double word) [only change RAM]

"5"-modification parameter value (double word) [RAM and EPROM are modified] not support.

Reponses logo PKW1 defines as below:

Table 7.10 Definition of response logo PKW1

Response label (From slave to host)	
Confirmation	Function
0	No response
1	Transmission parameter value (one word)
2	Transmission parameter value (two word)
3	Task can not be executed and returns the following error number: 0: Illegal parameter number 1: Parameter values can not be changed (read-only parameter) 2: Out of setting value range 3: The sub-index number is not correct 4: Setting is not allowed (only reset) 5: Data type is invalid 6: The task could not be implemented due to operational status 7: Request isn't supported. 8: Request can't be completed due to communication error 9: Fault occurs when write operation to stationary store 10: Request fails due to timeout 11: Parameter can not be assigned to PZD

Response label (From slave to host)	
Confirmation	Function
	12: Control word bit can't be allocated 13: Other errors
4	No parameter change rights

Example for PKW:

Example 1: Read parameter value

Read keypad setting frequency value (the address of keypad setting frequency is 4) which can be achieved by setting PKW1 as 1, PKW2 as 4, return value is in PKW4.

Request (From master to inverter):

	PKW1	PKW2	PKW3	PKW4	CW	PZD2	PZD3	...	PZD12
Request	00	01	00	04	00	00	00	00	xx xx xx xx xx xx ... xx xx

Response (From inverter to host)

	PKW1	PKW2	PKW3	PKW4	CW	PZD2	PZD3	...	PZD12
Response	00	01	00	04	50	00	xx	xx	xx xx xx ... xx xx

Example 2: Modify the parameter values (RAM and EEPROM are modified)

Modify keypad settings frequency value (the address of keypad setting frequency is 4) which can be achieved by setting PKW1 as 2; PKW2 as 4, modification value (50.00) is in PKW4.

Request (From master to inverter):

	PKW1	PKW2	PKW3	PKW4	CW	PZD2	PZD3	...	PZD12
Request	00	02	00	04	00	00	50	00	xx xx xx xx xx xx ... xx xx

Response (From inverter to host)

	PKW1	PKW2	PKW3	PKW4	CW	PZD2	PZD3	...	PZD12
Response	00 01	00 04	00 00	50 00	xx xx	xx xx	xx xx	...	xx xx

0001: Response (Parameter values refreshed)

Example for PZD:

Transmission of PZD area is achieved through inverter function code; please refer to relevant INVT inverter user manual to know relevant function code.

Example 1: Read process data of inverter

Inverter parameter selects "8: Run frequency" as PZD3 to transmit which can be achieved by setting Pd.14 as 8. This operation is mandatory until the parameter is instead of others.

Request (From master to inverter):

	PKW1	PKW2	PKW3	PKW4	CW	PZD2	PZD3	...	PZD12
Response	xx xx	xx xx	xx xx	xx xx	xx xx	xx xx	00 0A	...	xx xx

Example 2: Write process data into inverter

Inverter parameter selects "2: Traction given" from PZD3 which can be achieved by setting Pd.03 as 2. In each request frame, parameters will use PZD3 to update until re-select a parameter.

Request (From master to converter):

	PKW1	PKW2	PKW3	PKW4	CW	PZD2	PZD3	...	PZD12
Response	xx xx	xx xx	xx xx	xx xx	xx xx	xx xx	00 00	...	xx xx

In each request frame contents of PZD3 are given by traction until re-select a parameter.

7.5.5 Fault information

CH-PA01 module is equipped with three fault display LEDs as shown is figure 7.27. The roles of these LEDs are as follows:

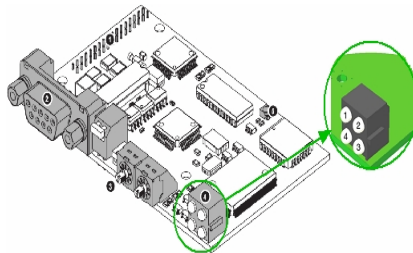

Figure 7.27 Fault display LEDs

LED No.	Name	Color	Function
1	Main display	Green	ON--Connection works
		Red	ON-Connection lost for ever Flashes- Connection lost for temporary
2	Online	Green	ON-module online and data can be exchanged. OFF-module is not in "online" state.
3	Offline	Red	ON-module offline and data can't be exchanged. OFF-module is not in "offline" state.
4	Fault	Red	Flicker frequency 1Hz-configuration error: The length of user parameter data sets is different from that of network configuration process during module initialization process. Flicker frequency 2Hz-user parameter data error: The length or content of user parameter data sets is different from that of network configuration process during module initialization process. Flicker frequency 4Hz-Profibus communication ASIC initialization error. OFF-Diagnostic closed.

7.6 Ethernet Communication Description

Ethernet function is integrated within CHV190, interface is CN12, please use standard Ethernet RJ45 cable with host software provided by INVT. All parameters within inverter can be easily set up, upload, download through host. It's easy to monitor up to more than 100 messages waveform real time within inverter.

CHV190 has "black box" function; inverter can keep 0.2s information waveform before the last fault. The information can be extracted through host computer software and it's easy to analyze fault cause.

8. TROUBLE SHOOTING

8.1 Fault and Trouble Shooting

CHV190 series is the inverter with perfect protection that can give full play to equipment performance, while be implemented effective protection. However, in the process of using it also encounter some trouble instructions, and please you analysis according to the following table to determine the reasons for the timely exclusion occurs. When confronted with equipment damage so that you can not be solved, please contact with your local distributor factoring, repairing centers or manufacturers to find a way of solution.

Fault code	Fault type	Reason	Solution
OUT1	IGBT Ph-U fault	1. Acc/Dec time is too short.	1. Increase Acc/Dec time.
OUT2	IGBT Ph-V fault	2. IGBT module fault.	2. Ask for support.
OUT3	IGBT Ph-W fault	3. Malfunction caused by interference. 4. Grounding is not properly.	3. Inspect external equipment and eliminate interference.
OC1	Over-current when acceleration	1. Short-circuit or ground fault occurred at inverter output.	1. Inspect whether motor damaged, insulation worn or cable damaged.
OC2	Over-current when deceleration	2. Load is too heavy or Acc/Dec time is too short.	2. Increase Acc/Dec time or select bigger capacity inverter.
OC3	Over-current when constant speed running	3. V/F curve is not suitable. 4. Sudden change of load.	3. Check and adjust V/F curve. 4. Check the load.
OV1	Over-voltage when acceleration	1. Dec time is too short and regenerative energy from the motor is too large.	1. Increase Dec time or connect braking resistor.
OV2	Over-voltage when deceleration	2. Input voltage is too high.	2. Decrease input voltage within specification.
OV3	Over-voltage when constant speed running		

Fault code	Fault type	Reason	Solution
UV	DC bus Under-voltage	1. Open phase occurred with power supply. 2. Momentary power loss occurred 3. Wiring terminals for input power supply are loose. 4. Voltage fluctuations in power supply are too large.	Inspect the input power supply or wiring.
OL1	Motor overload	1. Motor drive heavy load at low speed for a long time. 2. Improper V/F curve 3. Improper motor's overload protection threshold (Pb.03) 4. Sudden change of load.	1. Select variable frequency motor. 2. Check and adjust V/F curve. 3. Check and adjust Pb.03. 4. Check the load.
OL2	Inverter overload	1. Load is too heavy or Acc/Dec time is too short. 2. Improper V/F curve 3. Capacity of inverter is too small.	1. Increase Acc/Dec time or select bigger capacity inverter. 2. Check and adjust V/F curve. 3. Select bigger capacity inverter.
SPI	Input phase failure	1. Open-phase occurred in power supply. 2. Momentary power loss occurred. 3. Wiring terminals	Check the wiring, installation and power supply.

Fault code	Fault type	Reason	Solution
		for input power supply are loose. 4. Voltage fluctuations in power supply are too large. 5. Voltage balance between phases is bad.	
SPO	Output phase failure	1. There is a broken wire in the output cable 2. There is a broken wire in the motor winding. 3. Output terminals are loose.	Check the wiring and installation.
OH1	Rectify overheat	1. Ambient temperature is too high. 2. Near heat source.	1. Install cooling unit. 2. Remove heat source.
OH2	IGBT overheat	3. Cooling fans of inverter stop or damaged. 4. Obstruction of ventilation channel 5. Carrier frequency too high.	3. Replace cooling fan 4. Clear the ventilation channel. 5. Decrease carrier frequency.
EF	External fault	Sx: External fault input terminal take effect.	Inspect external equipment.
CE	Communication fault	1. Improper baud rate setting. 2. Receive wrong data. 3. Communication is	1. Set proper baud rate. 2. Check communication

Fault code	Fault type	Reason	Solution
		interrupted for Long time.	devices and signals.
ITE	Current detection fault	1. Wires or connectors of control board are loose. 2. Hall sensor is damaged. 3. Amplifying circuit is abnormal.	1. Check the wiring. 2. Ask for support.
TE	Autotuning fault	1. Improper setting of motor rated parameters. 2. Overtime of autotuning.	1. Set rated parameters according to motor nameplate. 2. Check motor's wiring.
PCE	Encoder fault	1. Signal wire of encoder was broken. 2. Encoder was damaged.	1. Inspect encoder connection. 2. Inspect whether the encoder output signal or not.
PCDE	Encoder reverse fault	Encoder signal wire was connected wrong.	Adjust encoder wiring.
EEP	EEPROM fault	Read/Write fault of control parameters.	Press STOP/RESET to reset. Ask for support.
PPPE	Magnetic pole position failure	The position of autotuning magnetic pole was detected wrong.	1. Check parameters of motor 2. Set rated parameters according to motor and autotuning again.
BCE	Brake unit fault	1. Braking circuit failure or brake tube damaged.	1. Inspect braking unit, replace braking tube. 2. Increase braking

Fault code	Fault type	Reason	Solution
		2. Too low resistance of externally connected braking resistor.	resistance.
-END-	Trial time reached	Trial time which determined by factory reached.	Contact supplier and ask for support.
LCD-E	LCD disconnected	1. LCD disconnected. 2. Material broken during tension control.	1. Press STOP/RST to reset, connect LCD then download or upload parameter. 2. Check material.
FAE	Brake feedback fault	The feedback of brake is error,	Inspect the controlling system of crane.
TbE	Contactor feedback fault	The feedback of contactor is error,	Inspect the controlling system of crane.
TPF	Torque verification fault	Torque verification is unsuccessful.	Check torque verify.
OFE	Motor speed fault	The actual motor speed exceeds the set speed.	Check control system and load.
TFT	Torque Monitoring fault	The monitoring of torque is error.	Check control system and load.
PCF	Profibus communication fault	The communication of Profibus is unsuccessful.	Check Profibus communication module and communication links.
ELS	Master-slave speed synchronization fault	The position error between master and slave exceeds the position bias limit	Adjust the master and slave position and recount the master-slave.
STEP	Multi-step speed rating fault	The lower classification contact is	Please connect the lower classification at

Fault code	Fault type	Reason	Solution
		disconnected, the higher classification contact is connected.	first, and then connect the more advanced classification.
STC	Operating lever fault	Operating lever has not returned to zero position.	Put the operating lever back zero.
ETH	Earth connection fault	Grounding is error.	Given speed is set by analog, GND disconnect.
CANE	CAN bus communication fault	Improper baud rate setting.	Set proper baud rate.
		Receive data error.	Press STOP/RST to reset. Ask for support.
		Communication is interrupted for Long time.	Check communication devices and signals.
OH3	Motor over-temperature fault	Motor temperature is too high.	Check motor.
		Temperature sensor is damaged.	Check temperature sensor.
		Temperature sensor wirings loose.	Check temperature sensor wiring.

8.2 Common Faults and Solutions

◆ Inverter may have following faults or malfunctions during operation, please refer to the following solutions.

No display after power on:

Inspect whether the voltage of power supply is the same as the inverter rated voltage or not with multi-meter. If the power supply has problem, inspect and solve it.

◆ After the power supply is switched off for a few minutes, inspect whether the three-phase rectify bridge is in good condition or not. If the rectification bridge is burst out, ask for support.

◆ Check the CHARGE light. If the light is off, the fault is mainly in the rectify bridge or the

buffer resistor. If the light is on, the fault may be lies in the switching power supply. Please ask for support.

Power supply air switch trips off when power on:

- ◆ Inspect whether the input power supply is grounded or short circuit. Please solve the problem.
- ◆ Inspect whether the rectify bridge has been burnt or not. If it is damaged, ask for support.

Motor doesn't move after inverter running:

- ◆ Inspect if there is balanced three-phase output among U, V, W. If yes, then motor could be damaged, or mechanically locked. Please solve it.
- ◆ If the output is unbalanced or lost, the inverter drive board or the output module may be damaged, ask for support.

Inverter displays normally when power on, but switch at the input side trips when running:

- ◆ Inspect whether the output side of inverter is short circuit. If yes, ask for support.
- ◆ Inspect whether ground fault exists. If yes, solve it.
- ◆ If trip happens occasionally and the distance between motor and inverter is too far, it is recommended to install output AC reactor.

9. MAINTENANCE



WARNING

- Maintenance must be performed according to designated maintenance methods.
- Maintenance, inspection and replacement of parts must be performed only by authorized personnel.
- After turning off the main circuit power supply, waiting for 10 minutes before performance maintenance or inspection.
- DO NOT directly touch components or devices of PCB board. Otherwise inverter can be damaged by electrostatic.
- After maintenance, all screws must be tightened.

9.1 Daily Maintenance

In order to prevent the fault of inverter to make it operate smoothly in high-performance for a long time, user must inspect the inverter periodically (within half year). The following table indicates the inspection content.

Items to be checked	Main inspections		Criteria
	Inspection content	Frequency	Means/Methods
Operation environment	(1) Temperature, humidity (2) Dust, vapor, leakage (3) Gases	(1) Point thermometer, hygrometer (2) Observation (3) Visual examination and smelling	(1) Ambient temperature shall be lower than 50℃; otherwise, the rated values should be decreased. Humidity shall meet the requirement (2) No dust accumulation, no traces of water leakage and no condensate. (3) No abnormal color and smell.

Items to be checked	Main inspections		Criteria
	Inspection content	Frequency	Means/Methods
Inverter	(1) Vibration (2) Cooling and heating (3) Noise	(1) Point thermometer comprehensive observation (2) Listening	(1) Smooth operation without vibration. (2) Fan is working in good condition. Speed and air flow are normal. (3) No abnormal heat. (4) No abnormal noise.
Motor	(3) Vibration (2) Heat (3) Noise	(1) Comprehensive observation Listening (2) Point thermometer (3) Listening	(1) No abnormal vibration and no abnormal noise. (2) No abnormal heat. (3) No abnormal noise.
Operation status parameters	(1) Power input voltage (2) Inverter output voltage (3) Inverter output current (4) Internal temperature	(1) Voltmeter (2) Rectifying voltmeter (3) Ammeter (4) Point thermometer	(1) Satisfying the specification. (2) Satisfying the specification. (3) Satisfying the specification. (4) Temperature rise is lower than 40°C.

9.2 Periodic Maintenance

Customer should check the drive every 3 months or 6 months according to the actual environment

1. Check whether the screws of control terminals are loose. If so, tighten them with a screwdriver;
 2. Check whether the main circuit terminals are properly connected; whether the mains cables are over heated;
 3. Check whether the power cables and control cables are damaged, check especially for any wear on the cable tube;
 4. Check whether the insulating tapes around the cable lugs are stripped;
 5. Clean the dust on PCBs and air ducts with a vacuum cleaner;
 6. For drives that have been stored for a long time, it must be powered on every 2 years.
- When supplying AC power to the drive, use a voltage regulator to raise the input voltage to

rated input voltage gradually. The drive should be powered for 5 hours without load.

7. Before performing insulation tests, all main circuit input/output terminals should be short-circuited with conductors. Then precede insulation test to the ground. Insulation test of single main circuit terminal to ground is forbidden; otherwise the drive might be damaged. Please use a 500V Mega-Ohm-Meter.

8. Before the insulation test of the motor, disconnect the motor from the drive to avoid damaging it.

9.3 Replacement of Wearing Parts

Fans and electrolytic capacitors are wearing part; please make periodic replacement to ensure long term, safety and failure-free operation. The replacement periods are as follows:

- ◆ Fan: Must be replaced when using up to 20,000 hours;
- ◆ Electrolytic Capacitor: Must be replaced when using up to 30,000~40, 000 hours.

10. COMMUNICATION PROTOCOL

10.1 Interfaces

RS485: asynchronous, half-duplex.

Default: 8-E-1, 19200bps. Please refer to Group PC: parameter settings.

10.2 Communication Modes

- (1) The protocol is Modbus protocol. Besides the common register Read/Write operation, it is supplemented with commands of parameters management.
- (2) The drive is a slave in the network. It communicates in 'point to point' master-slave mode. It will not respond to the command sent by the master via broadcast address.
- (3) In the case of multi-drive communication or long-distance transmission, connecting a 100~120Ω resistor in parallel with the master signal line will help to enhance the immunity to interference.

10.3 Protocol Format

Modbus protocol supports both RTU and ASCII mode. The frame format is illustrated as follows:

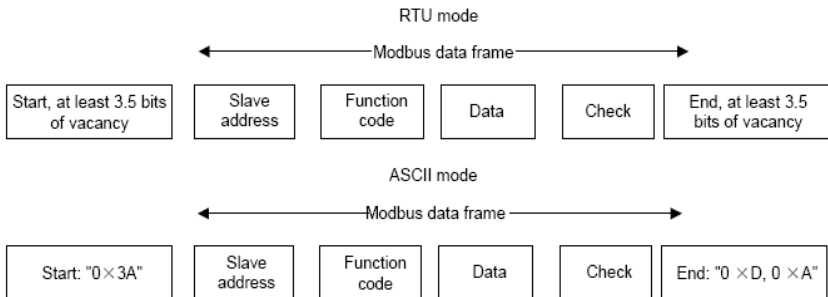

Modbus adopts "Big Endian" representation for data frame. This means that when a numerical quantity larger than a byte is transmitted, the most significant byte is sent first.

RTU mode

In RTU mode, the Modbus minimum idle time between frames should be no less than 3.5 bytes. The checksum adopts CRC-16 method. All data except checksum itself sent will be counted into the calculation. Please refer to section: CRC Check for more information.

Note that at least 3.5 bytes of Modbus idle time should be kept and the start and end idle time need not be summed up to it.

The table below shows the data frame of reading parameter 002 from slave node address

1.

Node adds.	Command	Data adds.		Read No.		CRC	
0x01	0x03	0x00	0x02	0x00	0x01	0x25	0xCA

The table below shows the reply frame from slave node address 1.

Node adds.	Command	Bytes No.	Data		CRC	
0x01	0x03	0x02	0x00	0x00	0xB8	0x44

ASCII mode

In ASCII mode, the frame head is "0x3A", and default frame tail is "0x0D" or "0x0A". The frame tail can also be configured by users. Except frame head and tail, other bytes will be sent as two ASCII characters, first sending higher nibble and then lower nibble. The data have 7/8 bits. "A"~"F" corresponds to the ASCII code of respective capital letter. LRC check is used. LRC is calculated by adding all the successive bytes of the message except the head and tail, discarding any carriers, and then two's complementing the result.

Example of Modbus data frame in ASCII mode:

The command frame of writing 0x0003 into address "0x1000" of slave node address 1 is shown in the table below:

LRC checksum = the complement of $(01+06+10+00+0x00+0x03) = 0xE5$.

	Frame head	Node adds.		Command		Data adds.			
Code		0	1	0	6	1	0	0	0
ASCII	3A	30	31	30	36	31	30	30	30

Data to write				LRC		Frame tail	
0	0	0	3	E	5	CR	LF
30	30	30	33	45	35	0D	0A

10.4 Protocol Function

Different respond delay can be set through drive's parameters to adapt to different needs. For RTU mode, the respond delay should be no less than 3.5 bytes interval, and for ASCII mode, no less than 1ms.

The main function of Modbus is to read and write parameters. The Modbus protocol supports the following commands:

0x03	Read inverter's function parameter and status parameters
0x06	Write single function parameter or command parameter to inverter

All drive's function parameters, control and status parameters are mapped to Modbus R/W data address.

The data addresses of each function parameters. Please refer to the sixth column of APPENDIX E.

The data address of control and status parameters please refer to the following table.

Parameter description	Address	Meaning of value	R/W feature
Control command	1000H	0001H: Up	W/R
		0002H: Down	
		0003H: JOG forward	
		0004H: JOG reverse	
		0005H: Stop	
		0006H: Coast to stop	
		0007H: Reset fault	
		0008H: JOG stop	
Inverter status	1001H	0001H: Forward running	R
		0002H: Reverse running	
		0003H: Standby	
		0004H: Fault	
Frequency source communication setting	2000H	Communication Setting Range (-10000~10000) Note: the communication setting is the percentage of the relative value (-100.00%~100.00%). If it is set as frequency source, the value is the percentage of the maximum frequency (P0.04). If it is set as PID (preset value or feedback value), the value is the percentage of the PID.	W/R
Virtual terminal input function setting	2001H	Setting range: 000H~03FFH. Each bit corresponds to S1~S10, HDI1, HDI2 and S6~S8 respectively. Notice: The functional code P5.01 should be set to the communication virtual terminal input function, and should also be unrelated to HDI1 and HDI2 input types.	W/R

Parameter description	Address	Meaning of value	R/W feature
Reserved	2002H		W
Reserved	2003H		W
Torque reference setting	2004H	Communication setting range (-10000~10000). Note:the value(-100.00%~100.00%) cooresponding to torque upper limit.	W
Torque upper limit setting	2005H	Communication setting range (-10000~10000). Note:the value(-100.00%~100.00%) corresponding to torque upper limit. Write command is valid.	W
Reserved	2006H		W
Motor temperature setting	2007H	Communication setting range (-2000~2000) is corresponding to (-200.0~200.0).	W
Status parameters	3000H	Output speed	R
	3001H	Reference speed	R
	3002H	DC Bus voltage	R
	3003H	Output voltage	R
	3004H	Output current	R
	3005H	Running frequency	R
	3006H	Output power	R
	3007H	Output torque	R
	3008H	Input terminal status	R
	3009H	Output terminal status	R
	300AH	Input of AI1	R
	300BH	Input of AI2	R
	300CH	Input of HDI	R
	300DH	Torque compensation	R
	300EH	Pole position	R
300FH ~ 3014H	Reserved	R	

Parameter description	Address	Meaning of value	R/W feature
	3015H	Torque direction (0: forward, 1: reverse)	R
	3016H	Device code	R
	4000H	****	R
Parameter lock password check address	4001H	55AAH	R
Parameter lock password command address	5000H	This address stores the fault type of inverter. The meaning of each value is same as P7.15.	R
Fault info address			

The above shows the format of the frame. Now we will introduce the Modbus command and data structure in details, which is called protocol data unit for simplicity. Also MSB stands for the most significant byte and LSB stands for the least significant byte for the same reason. The description below is data format in RTU mode. The length of data unit in ASCII mode should be doubled.

Protocol data unit format of reading parameters:

Request format:

Protocol data unit	Data length (bytes)	Range
Command	1	0x03
Data address	2	0~0xFFFF
Read number	2	0x0001~0x0010

Reply format (success):

Protocol data unit	Data length (bytes)	Range
Command	1	0x03
Returned byte number	2	2* Read number
Content	2* Read number	

If the command is reading the type of inverter (data address 0x3016), the content value in reply message is the device code:

The high 8 bit of device code is the type of the inverter, and the low 8 bit of device code is

the sub type of inverter.

For details, please refer to the following table:

High byte	Meaning	Low byte	Meaning
00	CHV	01	Universal type
		02	For water supply
		03	Middle frequency 1500HZ
		04	Middle frequency 3000HZ
01	CHE	01	Universal type
		02	Middle frequency 1500HZ
02	CHF	01	Universal type

If the operation fails, the inverter will reply a message formed by failure command and error code. The failure command is (Command+0x80). The error code indicates the reason of the error; see the table below:

Value	Name	Mean
01H	Illegal command	The command from master can not be executed. The reason maybe: 1. This command is only for new version and this version can not realize. 2. Slave is in fault status and can not execute it.
02H	Illegal data address.	Some of the operation addresses are invalid or not allowed to access.
03H	Illegal value	When there are invalid data in the message framed received by slave. Note: This error code does not indicate the data value to write exceed the range, but indicate the message frame is an illegal frame.
06H	Slave busy	Inverter is busy (EEPROM is storing).
10H	Password error	The password written to the password check address is not same as the password set by P7.00.
11H	Check error	The CRC (RTU mode) or LRC (ASCII mode) check not passed.

Value	Name	Mean
12H	Written not allowed.	It only happen in write command, the reason maybe: 1. The written data exceeds the parameter range. 2. The parameter should not be modified now. 3. The terminal has already been used.
13H	System locked	When password protection take effect and user does not unlock it, write/read the function parameter will return this error.

Protocol data unit format of writing single parameter:

Request format:

Protocol data unit	Data length (bytes)	Range
Command	1	0x06
Data address	2	0~0xFFFF
Write content	2	0~0xFFFF

Reply format (success):

Protocol data unit	Data length (bytes)	Range
Command	1	0x06
Data address	2	0~0xFFFF
Write content	2	0~0xFFFF

If the operation fails, the inverter will reply a message formed by failure command and error code. The failure command is (Command + 0x80). The error code indicates the reason of the error; see table 1.

10.5 Notice

10.5.1 Between frames, the span should not less than 3.5 bytes interval; otherwise, the message will be discarded.

10.5.2 Be cautious to modify the parameters of PC group through communication, otherwise may cause the communication interrupted.

10.5.3 In the same frame, if the spans between two .near bytes more than 1.5 bytes interval, the behind bytes will be assumed as the start of next message so that communication will failure.

10.6 CRC Check

For higher speed, CRC-16 uses tables. The following are C language source code for

CRC-16.

```

unsigned int crc_cal_value(unsigned char *data_value,unsigned char data_length)
{
int i;
unsigned int crc_value=0xffff;
while(data_length--)
{
crc_value^=*data_value++;
    for(i=0;i<8;i++)
    {
if(crc_value&0x0001)crc_value=(crc_value>>1)^0xa001;
        else crc_value=crc_value>>1;
    }
}
return(crc_value);
}
    
```

10.7 Example

10.7.1 RTU mode, read 2 data from 0004H

The request command is:

START	T1-T2-T3-T4 (transmission time of 3.5 bytes)
Node address	01H
Command	03H
High byte of start address	00H
Low byte of start address	04H
High byte of data number	00H
Low byte of data number	02H
Low byte of CRC	85H
High byte of CRC	CAH
END	T1-T2-T3-T4 (transmission time of 3.5 bytes)

The reply is :

START	T1-T2-T3-T4 (transmission time of 3.5 bytes)
Node address	01H
Command	03H
Returned byte number	04H

Higher byte of 0004H	13H
Low byte of 0004H	88H
High byte of 0005H	00H
Low byte of 0005H	00H
Low byte of CRC	7EH
High byte of CRC	9DH
END	T1-T2-T3-T4 (transmission time of 3.5 bytes)

10.7.2 ASCII mode, read 2 data from 0004H:

The request command is:

START	‘:’
Node address	‘0’
	‘1’
Command	‘0’
	‘3’
High byte of start address	‘0’
	‘0’
Low byte of start address	‘0’
	‘4’
High byte of data number	‘0’
	‘0’
Low byte of data number	‘0’
	‘2’
LRC CHK Hi	‘F’
LRC CHK Lo	‘6’
END Lo	CR
END Hi	LF

The reply is

START	‘:’
Node address	‘0’
	‘1’
Command	‘0’
	‘3’
Returned byte number	‘0’
	‘4’

Higher byte of 0004H	'1'
	'3'
Low byte of 0004H	'8'
	'8'
High byte of 0005H	'0'
	'0'
Low byte of 0005H	'0'
	'0'
LRC CHK Lo	5'
LRC CHK Hi	'D'
END Lo	CR
END Hi	LF

10.7.3 RTU mode, write 5000 (1388H) into address 0004H, slave node address 02.

The request command is:

START	T1-T2-T3-T4 (transmission time of 3.5 bytes)
Node address	02H
Command	06H
High byte of data address	00H
Low byte of data address	04H
High byte of write content	13H
Low byte of write content	88H
Low byte of CRC	C5H
High byte of CRC	6EH
END	T1-T2-T3-T4 (transmission time of 3.5 bytes)

The reply command is:

START	T1-T2-T3-T4 (transmission time of 3.5 bytes)
Node address	02H
Command	06H
High byte of data address	00H
Low byte of data address	04H
High byte of write content	13H
Low byte of write content	88H
Low byte of CRC	C5H
High byte of CRC	6EH

END	T1-T2-T3-T4 (transmission time of 3.5 bytes)
-----	--

10.7.4 ASCII mode, write 5000 (1388H) into address 0008H, slave node address 02.

The request command is:

START	‘:’
Node address	‘0’
	‘2’
Command	‘0’
	‘6’
High byte of data address	‘0’
	‘0’
Low byte of data address	‘0’
	‘4’
High byte of write content	‘1’
	‘3’
Low byte of write content	‘8’
	‘8’
LRC CHK Hi	‘5’
LRC CHK Lo	‘9’
END Lo	CR
END Hi	LF

The reply command is:

START	‘:’
Node address	‘0’
	‘2’
Command	‘0’
	‘6’
High byte of data address	‘0’
	‘0’
Low byte of data address	‘0’
	‘4’
High byte of write content	‘1’
	‘3’
Low byte of write content	‘8’
	‘8’

LRC CHK Hi	'5'
LRC CHK Lo	'9'
END Lo	CR
END Hi	LF

10.7.5 RTU mode, diagnose that the asked data bytes of address 01H should be the same as responds.

The request command is:

START	T1-T2-T3-T4
Node address	01H
Command	08H
High byte of data address	00H
Low byte of data address	00H
High byte of write content	12H
Low byte of write content	ABH
Low byte of CRC	ADH
High byte of CRC	14EH
END	T1-T2-T3-T4 (transmission time of 3.5 bytes)

The reply command is:

START	T1-T2-T3-T4 (transmission time of 3.5 bytes)
Node address	01H
Command	08H
High byte of data address	00H
Low byte of data address	00H
High byte of write content	12H
Low byte of write content	ABH
Low byte of CRC	ADH
High byte of CRC	14H
END	T1-T2-T3-T4 (transmission time of 3.5 bytes)

10.7.6 ASCII mode, diagnose that the asked data bytes of address 01H should be the same as responds.

The request command is:

START	':'
Node address	'0'
	'1'

Command	'0'
	'8'
High byte of data address	'0'
	'0'
Low byte of data address	'0'
	'0'
High byte of write content	'1'
	'2'
Low byte of write content	'A'
	'B'
LRC CHK Hi	'3'
LRC CHK Lo	'A'
END Lo	CR
END Hi	LF

The reply command is:

START	∴
Node address	'0'
	'1'
Command	'0'
	'8'
High byte of data address	'0'
	'0'
Low byte of data address	'0'
	'0'
High byte of write content	'1'
	'2'
Low byte of write content	'A'
	'B'
LRC CHK Hi	'3'
LRC CHK Lo	'A'
END Lo	CR
END Hi	LF

APPENDIX A APPLICATION MODE DESCRIPTION

A.0 Open loop sequence

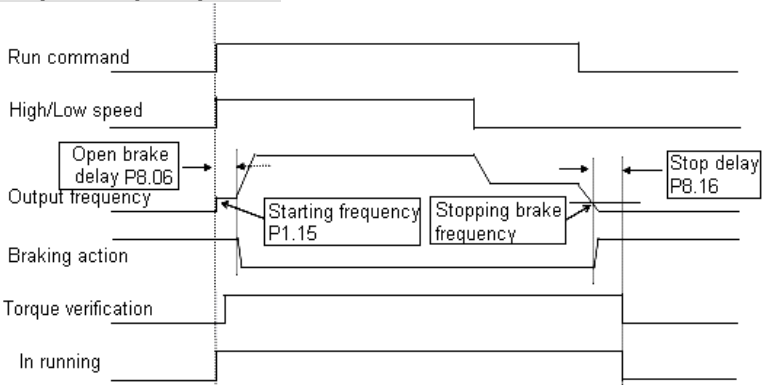

Figure A.1 Open loop sequential

Detailed information of P1.15, P8.06, P8.09 and P8.16 refer to the Chapter 6.

Open loop running sequential brief:

1. Inverter receives the UP/DOWN running and speed command from controller, and then inverter startup from 0 to starting speed P1.15. After delay time of P8.06, inverter output open brake control signal.
2. Controller block UP/DOWN and speed command, the inverter will coast to stop, when the speed reaches the brake frequency P8.09, the inverter will output brake instruction, after the delay time P8.16, the inverter stops and output motor stop signal.

A.1 Close loop sequence

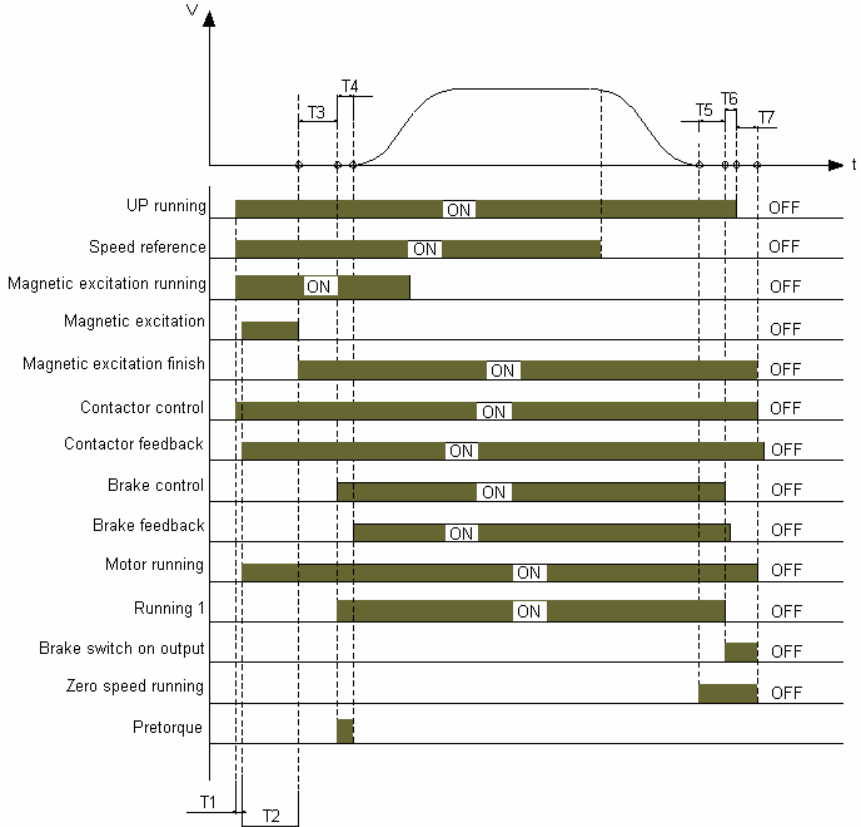

Figure A.2 Close loop vector control sequence diagram

Symbol	Details
T1	P8.08
T2	P8.23
T3	P8.06
T4	P8.07
T5	P8.05
T6	The waiting time is calculated from output brake command to receiving external signal of controller. It depends on external command.
T7	P8.16

Detailed information of P8.05, P8.06, P8.07, P8.08, P8.16 and P8.23 refer to the Chapter

6.

Close loop running sequential brief:

1. Inverter receives the UP/DOWN running and magnetic excitation from controller, Inverter outputs contactor switch on control instruction and then receive its feedback instruction after delay time T1, T1 depends on contactor hardware delay time. P8.08 definite maximum delay time. If $T1 > P8.08$, the inverter will show fault and stop.
2. After the motor running and inverter magnetic excitation running T2, inverter output excitation finish signal and start to zero speed running for T3, then the inverter output brake switch on signal and provides a pretorque for motor.
3. After the time T4, inverter receive brake feedback signals to confirm the brake is switch on, meanwhile, inverter start to accelerate according to S curve. T4 depends on the brake switching time. P8.07 definite maximum delay time. If $T4 > P8.07$, the inverter will show fault and stop.
4. After the controller cutting off speed instruction, inverter begins to decelerate according to S curve, when the speed reaches the threshold of stopping brake frequency. Inverter will output brake instruction after delay time T5, which demand controller cut off UP/DOWN command and output zero speed running signal.
5. The controller receives stopping command after T6, then inverter will stop after inverter T7. meanwhile, inverter should output contactor loose and motor stop signal until the complete process finish.

Notice: the logical is suitable for contactor and brake signal of inverter, If it is not used for controlling brake, Running 1 and brake switch on signal can be used for brake control of inverter.

APPENDIX B APPLICATION MODE DESCRIPTION

B.0 General Application Mode

General application mode wiring diagram is as follows:

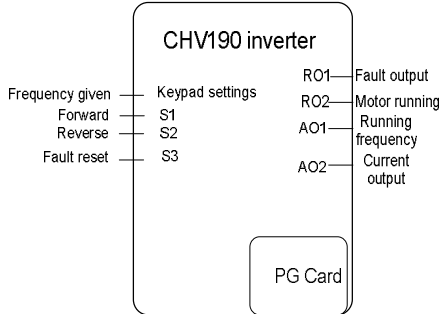

If set P0.11=0, general mode is valid, I/O signal settings and functions are set as default.

General application mode parameter settings are as follows:

Function code	Name	Selection	Description
P0.01	Run command source	1	Terminal command channel (LED flashing)
P0.02	Speed command selection	0	Keypad settings
P5.01	S4, S5 input type	0	ON/OFF input
P5.02	S1 terminal function	1	Forward (FWD)
P5.03	S2 terminal function	2	Reverse (REV)
P5.04	S3 terminal function	6	Fault reset (RET)
P6.04	Relay 1 output selections	4	Fault output
P6.05	Relay 2 output selections	1	Motor running
P6.07	AO1 output selection	0	Running frequency
P6.08	AO2 output selection	1	Setting frequency

B.1 Operating Lever Mode

Operating lever mode wiring diagram is as follows:

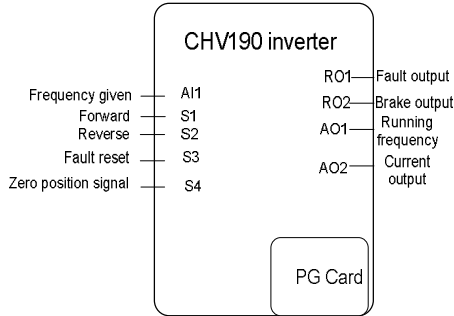

If set P0.11=1, operating lever mode is valid which connect to analog I/O terminal directly. Speed is given by analog AI1, digital terminal S1 and S2 control crane running up and down. If inverter receives two directions simultaneously, it will coast to stop; keypad will not display the fault information.

Operating lever zero position detection is valid, if you set P8.48=1, when inverter stopped, it can be restart after operating lever back to zero position and P8.49 (delay time of operating lever zero position).

When operating lever goes back to the zero position. Speed reference of AI1 is bigger than 1V, it may be ground fault, and keypad displays ground fault information.

Operating lever mode parameter settings are as follows:

Function code	Name	Selection	Description
P0.01	Run command source	1	Terminal command channel (LED flashing)
P0.02	Speed command selection	1	Analog AI1 given
P1.09	Straight-line acceleration time	4.0s	Acceleration time
P1.10	Straight-line deceleration time	4.0s	Deceleration time
P5.01	S4, S5 input type selection	0	ON/OFF input
P5.02	S1 terminal function	1	Forward (FWD)
P5.03	S2 terminal function	2	Reverse (REV)
P5.04	S3 terminal function	6	Fault reset (RET)
P5.05	S4 terminal function	24	Zero position signal
P6.04	Relay 1 output	4	Fault output

Function code	Name	Selection	Description
P6.05	Relay 2 output	7	Brake output
P6.07	AO1 output	0	Running frequency
P6.08	AO2 output	4	Current output
P8.04	Brake, contactor control	1	Brake is controlled by inverter
P8.16	Inverter stop delay time	0.25s	Delay time of stop

B.2 Remote Control Mode

Remote control model wiring diagram is as follows:

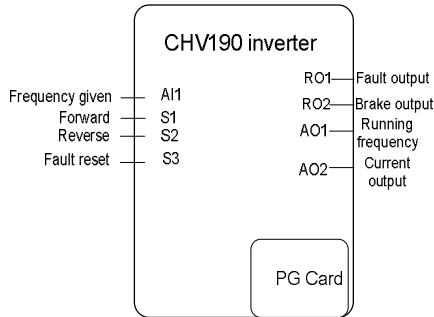

If set P0.11=2, remote control mode is valid when operating lever is connected to wireless controller or PLC.

Speed is given by analog AI1, digital terminal S1 and S2 control crane running up and down. If inverter receives two directions simultaneously, it will coast to stop; keypad will not display the fault information.

Zero-position detection is invalid in this mode.

Remote control mode parameter settings are as follows:

Function code	Name	Selection	Description
P0.01	Run command source	1	Terminal command channel (LED flashing)
P0.02	Speed command selection	1	Analog AI1 given
P1.09	Linear acceleration time	4.0s	Acceleration time
P1.10	Linear deceleration time	4.0s	Deceleration time
P5.01	S4, S5 input type	0	ON/OFF input
P5.02	S1 terminal function	1	Forward (FWD)

Function code	Name	Selection	Description
P5.03	S2 terminal function	2	Reverse (REV)
P5.04	S3 terminal function	6	Fault reset (RET)
P6.04	Relay 1 output	4	Fault output
P6.05	Relay 2 output	7	Brake output
P6.07	AO1 output	0	Running frequency
P6.08	AO2 output	4	Current output
P8.04	Brake, contactor control	1	Brake is controlled by inverter
P8.16	Inverter stop delay time	0.25s	Delay time of stop

B.3 Hierarchical Operating Lever Mode

Hierarchical operating lever mode wiring diagram is as follows:

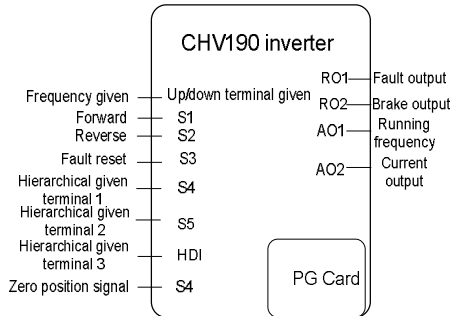

If set P0.11=3, hierarchical operating lever mode is valid when hierarchical operating lever is connected to the digital input I/O of inverter.

Digital terminal S1 and S2 control crane running up and down. If inverter receives two directions simultaneously, it will coast to stop; keypad will not display the fault information. Speed is given by multi-step function which supports up to 6 different speeds. Direction command gives the first level contacts and the other five level contacts. Hierarchical contacts can be connected to any digital input S terminal, corresponding speed given is set by P1.00 to P1.05, and the system default setting is 4 levels.

Speed reference of hierarchical contacts should be switched on from low bit to high. The higher contacts can be switch on only when lower ones are on. If the opposite situation appears, inverter will display hierarchical operating lever fault and stops.

Operating lever zero position detection is valid, if you set P8.48=1, when inverter stopped, it can be restart after operating lever back to zero position and P8.49 (delay time of operating lever zero position).

Function code	Name	Selection	Description
P0.01	Run command source	1	Terminal command channel (LED flashing)
P0.02	Speed command source	8	Hierarchical multi-step speed given
P1.09	Linear acceleration time	4.0s	Acceleration time
P1.10	Linear deceleration time	4.0s	Deceleration time
P5.00	HDI input type	1	HDI as switch input
P5.01	S4, S5 input type	0	ON/OFF input
P5.02	S1 terminal function	1	Forward (FWD)
P5.03	S2 terminal function n	2	Reverse (REV)
P5.04	S3 terminal function	6	Fault reset (RET)
P5.05	S4 terminal function	25	Hierarchical given terminal 1
P5.06	S5 terminal function	26	Hierarchical given terminal 2
P5.07	HDI1 terminal function	27	Hierarchical given terminal 3
P5.08	S7 terminal function	24	Zero position signal (Selection I/O extension card)
P6.04	Relay 1 output	4	Fault output
P6.05	Relay 2 output	7	Brake output
P6.07	AO1 output	0	Running frequency
P6.08	AO2 output	4	Current output
P8.04	Brake, contactor control	1	Brake is controlled by inverter
P8.16	Inverter stop delay time	0.25s	Delay time of stop

B.4 Hierarchical Remote Control Mode

Hierarchical remote control mode wiring diagram is as follows:

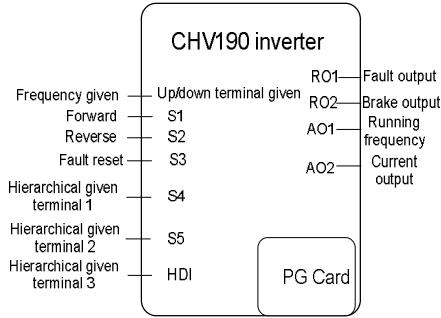

If set P0.11=4, hierarchical remote control mode is valid when digital input for hierarchical remote control is connected to hierarchical remote controller or PLC.

Digital terminal S1 and S2 control crane running up and down. If inverter receives two directions simultaneously, it will coast to stop; keypad will not display the fault information. Speed is given by multi-step function which supports up to 6 different speeds. Hierarchical contacts can be connected to any digital input S terminal; corresponding speed given is set by P1.00 to P1.05.

Zero position detection and hierarchical operating lever fault aren't necessary in the mode. Hierarchical remote mode parameter settings are as follows:

Function code	Name	Selection	Description
P0.02	Speed command source	8	Terminal command channel (LED flashing)
P1.09	Linear acceleration time	4.0s	Hierarchical multi-step speed given
P1.10	Linear deceleration time	4.0s	Acceleration time
P5.00	HDI input type	1	Deceleration time
P5.01	S4, S5 input type	0	HDI as switch input
P5.02	S1 terminal function	1	Switch input
P5.03	S2 terminal function	2	Forward (FWD)
P5.04	S3 terminal function	6	Reverse (REV)
P5.05	S4 terminal function	25	Fault reset (RET)
P5.06	S5 terminal function	26	Hierarchical given terminal 1
P5.07	HDI1 terminal function	27	Hierarchical given terminal 2
P6.04	Relay 1 output	4	Fault output

Function code	Name	Selection	Description
P6.05	Relay 2 output	7	Brake output
P6.07	AO1 output	0	Running frequency
P6.08	AO2 output	4	Current output
P8.04	Brake, contactor control	1	Brake is controlled by inverter
P8.16	Inverter stop delay time	0.25s	Delay time of stop

B.5 Electric Potential Mode

Electric potential mode wiring diagram is as follows:

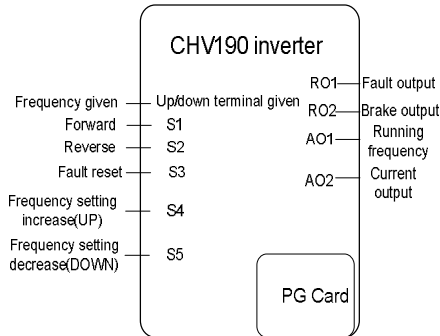

If set P0.11= 5, Electric potential mode is valid which use a button provide reference of acceleration and deceleration commands.

Digital terminal S1 and S2 control crane running up and down. If inverter receives two directions simultaneously, it will coast to stop; keypad will not display the fault information.

Acceleration and deceleration commands are connected to S4 and S5. If acceleration contact closes after inverter starts accelerating toward 100% speed with certain slope. If acceleration signal is removed before reaching 100%, inverter stops accelerating and runs at current speed. If acceleration signal apply again, inverter accelerates according to 100% speed with certain slope again. Deceleration command is the same as acceleration command.

If direction command is removed, inverter decelerates toward zero speed with certain slope. If direction command is given again before inverter stops, it stops deceleration and runs at current speed.

Electric potential mode parameter settings are as follows:

Function code	Name	Selection	Description
P0.01	Run command source	1	Terminal command channel (LED flashing)
P0.02	Speed command source	5	Up/down terminal given
P1.09	Linear acceleration time	4.0s	Acceleration time
P1.10	Linear deceleration time	4.0s	Deceleration time
P5.01	S4, S5 input type	0	ON/OFF input
P5.02	S1 terminal function	1	Forward (FWD)
P5.03	S2 terminal function	2	Reverse (REV)
P5.04	S3 terminal function	6	Fault reset (RET)
P5.05	S4 terminal function	22	Frequency setting increase (UP)
P5.06	S5 terminal function	23	Frequency setting decrease (DOWN)
P6.04	Relay 1 output	4	Fault output
P6.05	Relay 2 output	7	Brake output
P6.07	AO1 output	0	Running frequency
P6.08	AO2 output	4	Current output
P8.04	Brake, contactor control	1	Brake is controlled by inverter
P8.16	Inverter stop delay time	0.25s	Delay time of stop

B.6 Master-slave Power Equilibrium Host Mode

Master-slave power balance host mode wiring diagram is as follows:

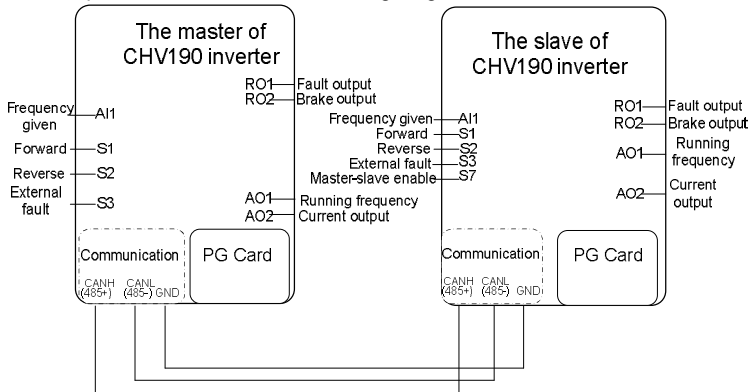

Notice: 485 communications (communications card and I/O expansion cards) and CAN communication (I/O expansion card) are valid in master-slave power balance host mode.

Master-slave control is used to distribute load among two or more motor to reach balance. When transmission device is driven by two or more motor and these motors are coupled by gears, chains or belts, then master-slave control function is needed.

An external control signal can be connected to host only which control slave by a serial communication link (CAN bus or 485 bus). The external signal can also be connected to both host and slave, while the communication only passes the host torque signal.

Host uses speed control and slave follows host's torque or speed given. There are three kinds of application in general.

1) When motor shaft of master and slave use flexible connection.

The host works as speed control and the slave should use speed control mode too because slight difference of speed between host and slave are permitted, please refer to example one for master-slave control.

2) When motor shaft of host and slave machine use rigid connection by gears, chains.

The slave should use torque control mode to make sure no speed differences among drive units. Please refer to example two for master-slave control.

3) The slave needs using both speed control and torque control in some applications. One digital input terminal is needed for switching between speed control and torque control.

Example one for master-slave control:

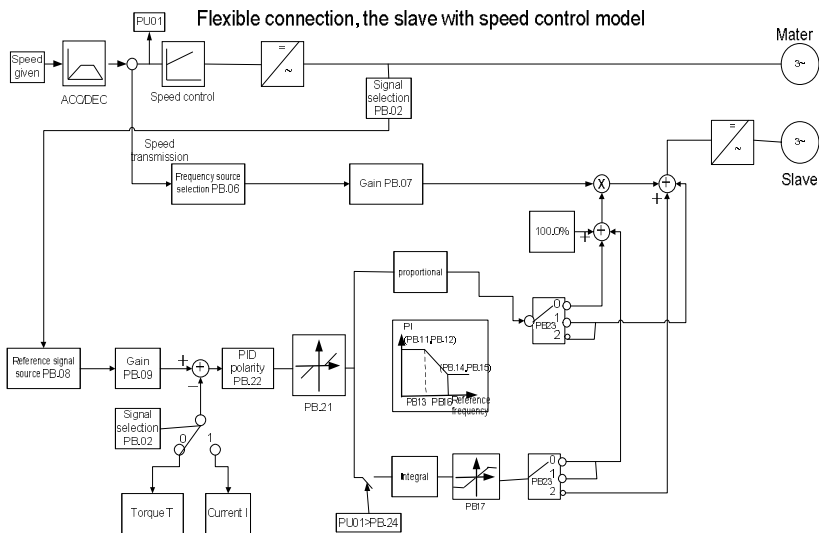

Notice:

- 1) Example one above is application control diagram for flexible load drive. The master and slave are connected by belts or other extendable materials (flexible load). Due to ductility of materials, some speed error between master and slave is permitted.
- 2) The master and slave both use speed control under this situation. The host sends the running frequency to the slave as frequency reference. At the same time, the slave receives current output torque (output current) of the host, and then compares with its own torque to do PID error calculation whose result will be used as the adjustment for the slave's current frequency reference. The master and slave can realize synchronization control and power balance at last.
- 3) In the master-slave control mode, the running command of the host is connected to fault signals of the slave, once the slave is fault; the host is not allowed to run.
- 4) There are three types mode for PID calculations of the slave depending on specific applications.
- 5) The meaning of $F_m > Pb.24$ is to make sure that the slave starts PID calculation after the host starts to prevent PID initial calculation accumulation of slave before host starting.

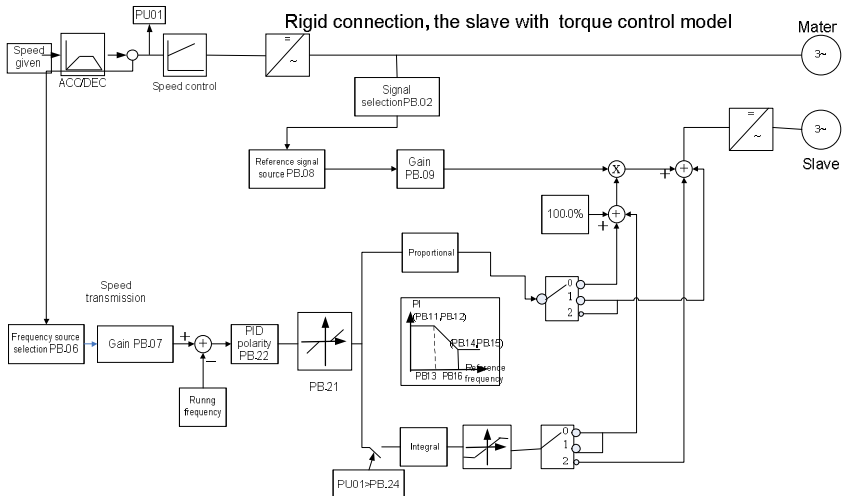
Example two for master-slave control:

Notice:

- 1) Example two above is application control diagram for rigid load drive. The connection between the master and the slave is fixed. It should be no speed error

between the master and the slave.

2) The master use speed control and the slave use torque control under this situation. The master sends output torque (output current) to the slave as the torque reference. At the same time, the slave receives running frequency of the host, and then compares with its own frequency to do PID error calculation, whose result will be used as the slave's adjustment current torque reference. The master and slave can realize synchronization control and power balance at last.

3) In the master-slave control mode, the running command of the host is connected to fault signals of the slave, once the slave is fault; the host is not allowed to run.

4) There are three types mode for PID calculations of the slave depending on specific applications.

5) The meaning of F_m> Pb.24 is to make sure that the slave starts PID calculation after the host starts to prevent PID initial calculation accumulation of slave before host starting.

If set P0.11=6, the master-slave power equilibrium host mode is valid when the inverter master-slave power equilibrium control mode is host under master-slave speed control host mode.

Digital terminal S1 and S2 control crane running up and down. If inverter receives two directions simultaneously, it will coast to stop; keypad will not display the fault information. Fault output of the slave should be connected to the external fault terminal of the host. Master-slave power equilibrium host mode parameter settings are as follows:

Function code	Name	Selection	Description
P0.01	Run command source	1	Terminal command channel (LED flashing)
P0.02	Speed command source	1	AI1 setting
P1.09	Linear acceleration time	4.0s	Acceleration time
P1.10	Linear deceleration time	4.0s	Deceleration time
P5.01	S4, S5 input type	0	ON/OFF input
P5.02	S1 terminal function	1	Forward (FWD)
P5.03	S2 terminal function	2	Reverse (REV)
P5.04	S3 terminal function	7	External fault (EF)
P6.04	Relay 1 output	4	Fault output
P6.05	Relay 2 output	7	Brake output
P6.07	AO1 output	0	Running frequency
P6.08	AO2 output	4	Current output

Function code	Name	Selection	Description
P8.04	Brake, contactor control	1	Brake is controlled by inverter
P8.16	Inverter stop delay time	0.25s	Delay time of stop
Pb.00	Master-slave type	1	Power balance model
Pb.01	Master-slave mode	1	The slave
Pb.04	Data sending of host communication enable	1	CAN communication sending

B.7 Master-slave Power Equilibrium Slave Mode

If set P0.11=7, the master-slave power equilibrium slave mode is valid when the inverter of the master-slave power equilibrium control mode is slave under master-slave power equilibrium slave mode.

Direction and speed commands of crane are given by the host.

Fault output of the slave should be connected to the external fault terminal of the host.

Master-slave power equilibrium slave mode parameter settings are as follows:

Function code	Name	Selection	Description
P0.01	Run command source	1	Terminal command channel (LED flashing)
P0.02	Speed command source	1	All setting
P1.09	Linear acceleration time	4.0s	Acceleration time
P1.10	Linear deceleration time	4.0s	Deceleration time
P5.01	S4, S5 input type	0	ON/OFF input
P5.04	S3 terminal function	7	External fault (EF)
P5.08	S7 terminal function	19	Master-slave enable (need I/O extension card)
P6.04	Relay 1 output	4	Fault output
P6.05	Relay 2 output	7	Brake output
P6.07	AO1 output	0	Running frequency
P6.08	AO2 output	4	Current output
P8.04	Brake, contactor control	1	Brake is controlled by inverter
P8.16	Inverter stop delay time	0.25s	Delay time of stop
Pb.00	Master-slave type	1	Power balance model

Function code	Name	Selection	Description
Pb.01	Master-slave mode	2	The slave
Pb.04	Data sending of host communication enable	1	CAN communication sending

B.8 Master-slave Speed Synchronization Host Mode

There are two different types wiring diagram for master-slave speed synchronization according to speed synchronous pulse counter source.

1. If set Pb.34=1 (internal encoder pulse counting), direction, speed command and position pulse counter of the slave are given by host communication, wiring diagram is as follows:

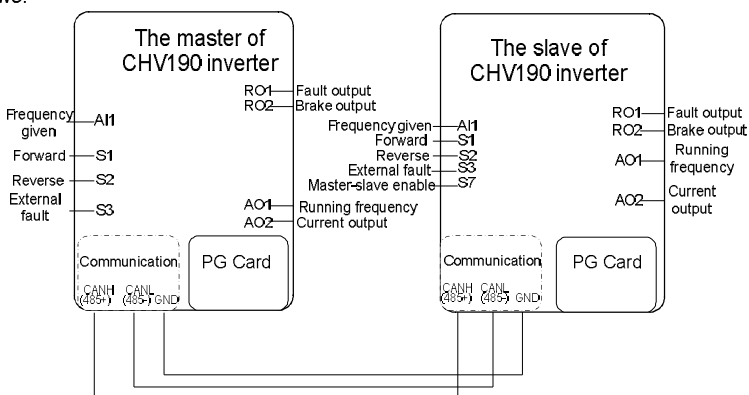

Notice: The communication of the figure above can be 485 communications (communication card and I/O expansion card) and CAN communication (I/O expansion card).

2. If set Pb.34=0 (external terminals S4, S5), direction and speed command of the slave are given by host communication; position pulse counter is given by external terminals S4, S5. Digital input terminal S4 is connected to PG card frequency division output of the host, while digital input terminal S5 is connected to the slave's. PG Card frequency division coefficients of the host and slave must be consistent.

Frequency division coefficient calculation formula is as follows:

$$K = \frac{\text{Motor maximum rotation speed (r/min)} \times \text{encoder pulses}}{5 \times 1024 \times 60}$$

Frequency division coefficients of the master and the slave must be greater or equal to that calculated one, wiring diagram is as follows:

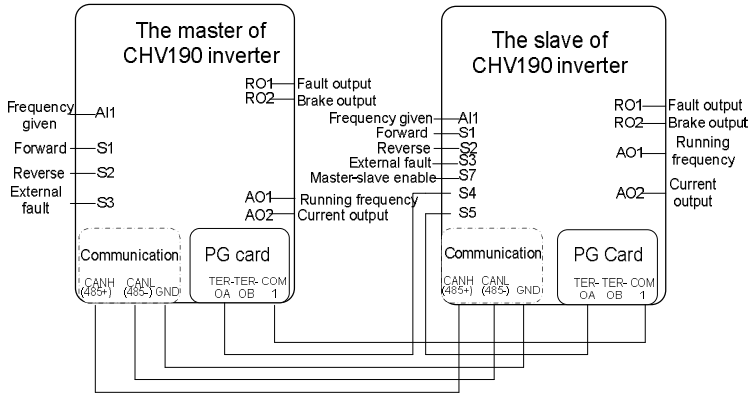

Notice: The communication of the figure above can be 485 communications (communication card and I/O expansion card) and CAN communication (I/O expansion card).

Master-slave speed synchronization is used for two motor running synchronously. The function requires two inverters both with pulse encoder feedback.

Master-slave speed synchronization function is comparing position counting values of the master and the slave. The deviation for the slave can be reduced to zero by adding a velocity correction given which is calculated by PID proportion coefficients one (Pb.11) and integral time one (Pb.12).

When position deviation exceeds Pb.29 (speed synchronous position error dead zone), the collection of slave is valid. If the correction value exceeds Pb.30 (speed synchronous regulator output limit), it will be limited to Pb.30. If position deviation of the master and slave exceeds Pb.28 (speed synchronous position deviation fault limit), the slave brakes and displays "ELS" on the keypad.

The speed of the slave is lower than Pb.31 (the minimum speed of speed synchronous output enable); the collection of slave is invalid. (Position deviations are still detected and will be used when new start command is given.)

Master-slave speed synchronization can enable and cut off by an external signal 19: the external signal is connected to the slave.

When the master-slave speed synchronous enables, only the host have start command and speed given is valid. The host sends start commands and speed given to the slave

through communication (CAN or 485 bus). Acceleration and deceleration time of the slave should be set equal to or less than that of the master. If there is no communication card, the master and slave should use the same run command and speed given, acceleration and deceleration time of the slave should be consistent with the master.

When the master-slave speed synchronization is cut off, the two inverters work in their own "normal mode", if master-slave synchronous speed is separated or integrated when the motor is running, the slave should decelerate to stop.

When gearbox reduction ratio of the master and slave is different, please set the value of master/slave speed ratio as Pb.07 (the gain frequency reference of slave). When each pulse corresponding to the distance of master/slave encoder output is different, Please use Pb.26 and Pb.27 to set pulse speed ratio of master and slave.

Master/slave unit pulse speed ratio = $Pb.26/Pb.27$. This scale factor multiplies position value of the slave only when the master-slave speed synchronization control is effective.

Control diagram is as follows:

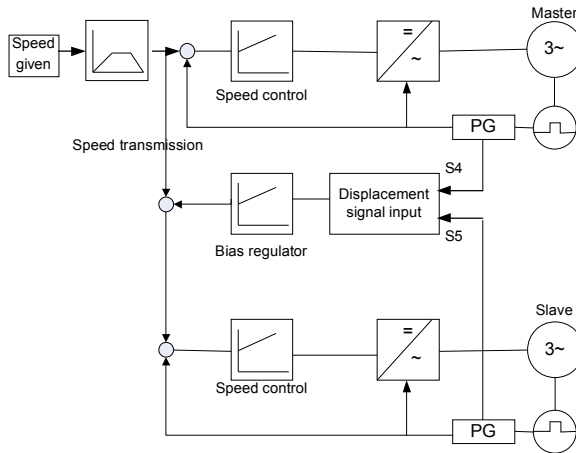

If set P0.11=8, the master-slave speed synchronization host mode is valid when the inverter of the master-slave speed synchronization control mode is host under master-slave speed synchronization host mode.

Digital terminal S1 and S2 control crane running up and down. If inverter receives two directions simultaneously, it will coast to stop; keypad will not display the fault information.

Fault output of the master should be connected to the external fault terminal of the slave.

Master-slave speed synchronous host mode parameter settings are as follows:

Function code	Name	Selection	Description
P0.01	Run command source	1	Terminal command channel (LED flashing)
P0.02	Speed command source	1	AI1 setting
P1.09	Linear acceleration time	4.0s	Acceleration time
P1.10	Linear deceleration time	4.0s	Deceleration time
P5.01	S4, S5 input type	0	ON/OFF input
P5.02	S1 terminal function	1	Forward (FWD)
P5.03	S2 terminal function	2	Reverse (REV)
P5.04	S3 terminal function	7	Fault reset (RET)
P6.04	Relay 1 output	4	Fault output
P6.05	Relay 2 output	7	Brake output
P6.07	AO1 output	0	Running frequency
P6.08	AO2 output	4	Current output
P8.04	Brake, contactor control	1	Brake is controlled by inverter
P8.16	Inverter stop delay time	0.25s	Delay time of stop
PA.06	485 communication protocol selection	1	Internal master-slave control protocol
Pb.00	Master-slave type selection	2	Speed synchronous mode
Pb.01	Master-slave mode selection	1	The master
Pb.04	Data sending of host communication enable	1	CAN communication sending

B.9 Master-slave Speed Synchronization Slave Mode

If set P0.11=9, the master-slave speed synchronization slave mode is valid when the inverter of the master-slave speed synchronization control mode is slave under master-slave speed synchronization slave mode.

Fault output of the slave should be connected to the external fault terminal of the host

Master-slave speed synchronous slave mode parameter settings are as follows:

Function code	Name	Function	Description
P0.01	Run command channel	1	Terminal command channel (LED flashing)

Function code	Name	Function	Description
P0.02	Speed command selection	1	AI1 setting
P1.09	Linear acceleration time	4.0s	Acceleration time
P1.10	Linear deceleration time	4.0s	Deceleration time
P5.01	S4, S5 input type	1	Master-slave synchronization counting input
P5.04	S3 terminal function	7	External fault (EF)
P5.05	S4 terminal function	0	Non-function (HDI is admitted)
P5.06	S5 terminal function	0	Non-function (HDI is admitted)
P5.08	S7 terminal function	19	Master-slave enable (I/O expansion cards)
P5.09	S8 terminal function	20	Master-slave speed synchronization counting reset
P6.04	Relay 1 output	4	Fault output
P6.05	Relay 2 output	7	Brake output
P6.07	AO1 output	0	Running frequency
P6.08	AO2 output	4	Current output
P8.04	Brake, contactor control	1	Brake is controlled by inverter
P8.16	Inverter stop delay time	0.25s	Delay time of stop
Pb.00	Master-slave type	2	Speed synchronous mode
Pb.01	Master-slave mode	2	The master
Pb.04	Data sending of host communication enable	1	CAN communication sending

APPENDIX C THE SELECTION GUIDE OF CHV190

C.1 Inverter Capacity Calculation

Inverter current is heavy for crane running up and down, the maximum starting torque and ACC/DEC torque of motor should be calculated. Please refer to details for inverter selection of crane running up and down, horizontal movement.

(1) The lifting mechanism

Motor shaft output power for lifting mechanism of gantry crane is as follows:

$$P_M = W * V / 6120 \eta$$

W - Rated lifting load weight of lifting mechanism, kg

V - Rated speed of lifting mechanism, m/min

η - Mechanical efficiency of lifting mechanism

Inverter capacity must be bigger than output required by load.

$$P_0 \text{ [KVA]} \geq k P_M / \eta \cos \phi$$

k - Overload coefficient 1.33

P_M - Motor shaft output power required by load, kW

η - Motor efficiency

$\cos \phi$ - Motor power factor

Starting torque required by lifting mechanism is 1.3-1.6 times of rated torque, considering the 125% overload requirements, maximum torque is required to be 1.6-2 times of rated torque, in order to make its safe use. CHV190 crane special inverter can afford up to 150% rated torque for 60s, the overload factor $k = 2/1.5 = 1.33$.

Current verification should be done after inverter capacity is chosen.

$$I_{CN} \geq k I_M$$

k - Current waveform correction factor ($k=1.05-1.1$ when PWM modulation mode)

I_{CN} - Inverter rated output current, A

I_M - Motor rated current of frequency power, A

There are two separate lifting mechanisms for general large-tonnage cranes; each lifting mechanism has two motors synchronously drive their wire reel, then upgrade hook by pulley multi-level reduction. The scheme of variable frequency timing system for lifting mechanism is one inverter for one motor. In order to improve dynamic characteristics and high torque output capability of low-speed transmission, each inverter uses speed closed-loop control with encoder pulse. Master-slave control scheme with power balance and speed synchronization control function is provided by CHV190 series inverter used between two inverters of each lifting mechanism. The program can achieve accurate

torque balance of two motors distribution and speed synchronization of two lifting mechanism.

(2) Horizontal movement mechanism

Horizontal movement mechanisms of cranes are classified to cart agency with big motor or small motor. Carts agencies use multi-motors drive scheme. As rotation inertia of crane horizontal movement mechanism is large, motor acceleration need larger starting torque, motor shaft output power P_M of crane horizontal movement mechanism is composed of load power P_j and acceleration power P_a .

$$P_M \geq P_j + P_a$$

As horizontal movement mechanism adopts one CHV190 inverter driving more than one motor, inverter capacity selection should follow formula as below.

$$I_{CN} \geq kI_M$$

$$I_{CN} \geq kI_M$$

k - Current waveform correction factor ($k=1.05-1.1$ when PWM modulation mode)

I_{CN} - Inverter rated output current, A

I_M - Motor rated current of frequency power, A

n – Motor number of inverter driven

C.2 Renewable Energy Treatment

The lifting and horizontal movement mechanism drive potential load running down or horizontally as emergency deceleration or downwind. Then motor works in regenerative state. Inverter transfer mechanical energy to electrical energy and feed back to DC circuit. The voltage of capacity of DC bus rose. If no necessary measures, when the voltage rises to protection limit and trip over voltage.

There are two schemes to deal with continuous renewable energy in high-performance engineering inverter.

① Dissipate the energy by resistor connecting to DC circuit

This way is called dynamic brake;

② Use renewable rectifier way to return regenerative energy to mains. This way is called regenerative braking.

Please refer to DBU and RBU manual for specific parameters and instructions.

C.2.1 Dynamic braking

Dynamic brake is composed of braking unit and braking resistor. Dynamic brake ability depends on permitted power of braking resistor. Renewable power P_M must meet the condition, $P_M < P_R$ (P_R is permitted power of braking resistor). If $P_M > P_R$, it is necessary

to reconsider deceleration time and load inertia. The following are ways to calculate PM of brake resistor and RB.

① Calculate renewable energy EM

② Calculate renewable energy to inverter PM

$$PM = E_M/t_0$$

PM- Effective regenerative power during braking, W

EM-Regenerative energy when emergency deceleration and running down, J

t₀-Braking cycle time, S

③ Select appropriate braking unit and braking resistor

Select appropriate braking unit and braking resistor; the following conditions must be met:

$$P_M < P_R \ \& \ P_M < P_{DB}$$

PM - Effective regenerative power during braking, W

PR - Power permission of resistor, W

P_{DB} - Power permission of braking unit, W

If PM > PR, it is necessary to reconsider deceleration time and load inertia.

④ Braking resistors calculation R_{B0}

Internal motor consumption can get about 20% braking torque in regeneration, even braking resistor is not set. R_{B0} can be calculated by following formula:

$$R_{B0} = V_C^2 / 1.027 (T_B - 0.2T_M) n_1$$

V_C - Voltage of DC circuit (about 700V), V

T_B - Braking torque, kg · m

T_M - Rated torque, kg · m

n₁ - Speed when motor begins to slow down, rpm

Discharge circuit of dynamic braking is composed of braking unit and braking resistor, the maximum current is limited by maximum allowable current of braking transistor, the minimum allowable value of braking resistor is R_{MIN} = V_C/I_C. Braking resistor should meet the following conditions:

$$R_{MIN} < R_B < R_{B0}$$

The selection above is based on accurate calculation, if accurate data can not be achieved in actual engineering calculation, the selection can also based on the following empirical formula:

① Regenerative power P_M of lifting mechanism

$$PM = Pb \times \eta_{total}$$

$$Pb = m \times g \times v$$

$$\eta_{total} = \eta_{mec} \times \eta_{mot} \times 0.98$$

Pb- Regenerative power

m- Lifting weight

v- Lifting speed

η_{mec} - Mechanical efficiency

η_{mot} - Motor efficiency

② Approximate calculation of braking resistors R_{B0}

$$R_{B0} = V_C^2 / PM$$

Horizontal movement mechanism is belong to friction load, braking unit and braking resistor can be set according to standard configuration of inverter (see table as below).

Inverter capacity kW (HP)	Brake unit		Brake resistor (100% brake torque, 10% usage)		
	Specifications	Number	Equivalent brake resistor	Equivalent brake power	Number
CHV190-018G-4	DBU-055-4	1	20Ω	6000W	1
CHV190-022G-4		1	20Ω	6000W	1
CHV190-030G-4		1	20Ω	6000W	1
CHV190-037G-4		1	13.6Ω	9600W	1
CHV190-045G-4		1	13.6Ω	9600W	1
CHV190-055G-4		1	13.6Ω	9600W	1
CHV190-075G-4		2	13.6Ω	9600W	2
CHV190-090G-4		2	13.6Ω	9600W	2
CHV190-110G-4		2	13.6Ω	9600W	2
CHV190-132G-4	DBU-160-4	1	4Ω	30000W	1
CHV190-160G-4		1	4Ω	30000W	1
CHV190-185G-4	DBU-220-4	1	3Ω	40000W	1
CHV190-200G-4		1	3Ω	40000W	1
CHV190-220G-4		1	3Ω	40000W	1
CHV190-250G-4	DBU-315-4	1	2Ω	60000W	1
CHV190-280G-4		1	2Ω	60000W	1
CHV190-315G-4		1	2Ω	60000W	1
CHV190-350G-4	DBU-220-4	2	3Ω	40000W	2
CHV190-400G-4		2	3Ω	40000W	2
CHV190-500G-4	DBU-315-4	2	2Ω	60000W	2

C.2.2 Regenerative braking

In order to return renewable power generative energy to grid, mains-side converter should be reversible. Mains-side converter of INVT's RBU has the same structure as inverter by adopting voltage detecting board with PWM control mode, which can control amplitude; phase of main-side voltage to make sure that the phase of AC input current is the same as voltage like sine waveform. The power factor is greater than 0.9, regenerative braking has 100% feedback capability to grid without auto-transformer.

C.2.3 Choices of renewable energy treatment

Dynamic braking control has the advantages of simple control, low cost, but energy-saving effect is not as good as regenerative braking.

Notice: Regenerative braking can be used only under stable grid voltage.

For sliding contact line powered cranes, we recommend using dynamic braking for reliability.

APPENDIX D RELATIVE DIMENSION OF INVERTER

D.1 External Dimension

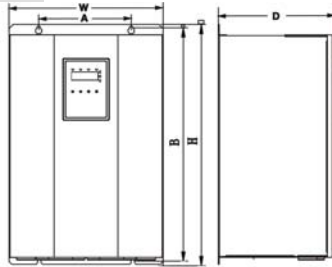

Figure D.1 Dimensions (18.5kW~110kW)

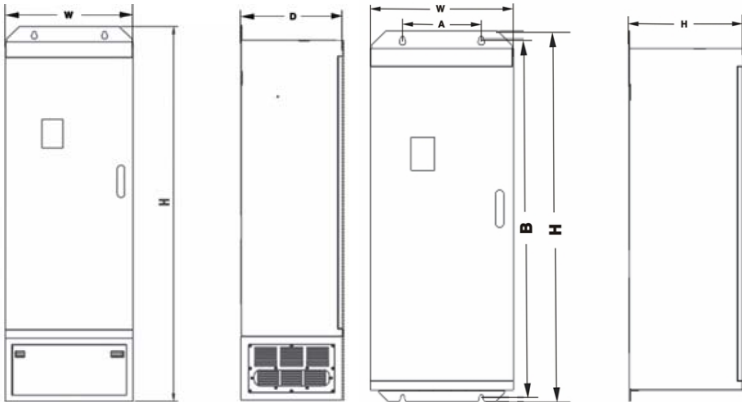

Figure D.2 Dimensions (132 kW~315kW)

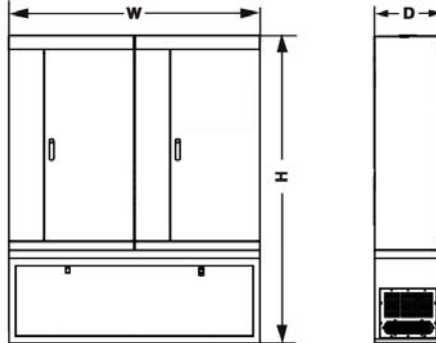

Figure D.3 Dimensions (350kW~500kW)

Power (kW)	Size	A (mm)	B (mm)	H (mm)	W (mm)	D (mm)	Installation hole (mm)
		Installation Dimension		External Dimension			
18.5~30	E	176	454.5	467	290	215	6.5
37~55	F	230.0	564.5	577.0	375.0	270.0	7.0
75~110	G	320.0	738.5	755.0	460.0	330.0	9.0
132~185	H (without base)	270	1233	1275	490	391	13
	H (with base)	—	—	1490	490	391	—
200~315	I (without base)	500	1324	1358	750	402	12.5
	I (with base)	—	—	1670	750	402	—
350~500	—	—	—	1950	1200	502	—

D.2 Dimensions of External Keypad

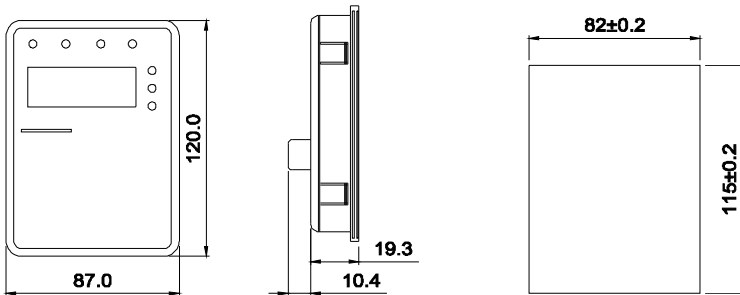

Figure D.4 Dimension of keypad

D.3 Installation Space

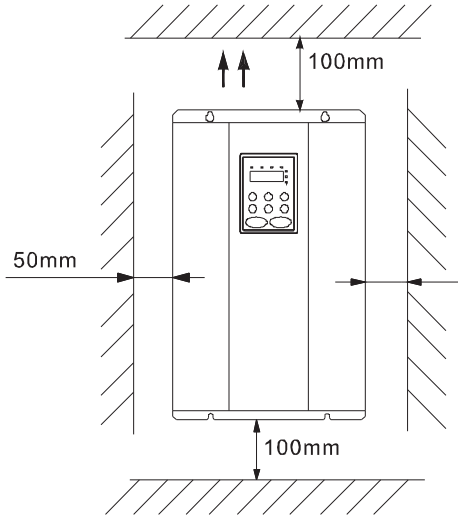

Figure D.5 Safety space

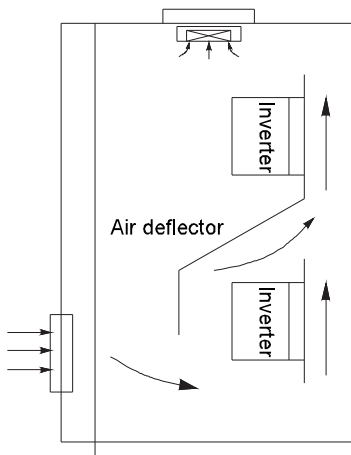

Figure D.6 Installation of multiple inverters

Notice: Add the air deflector when apply the up-down installation.

D.4 Disassembly

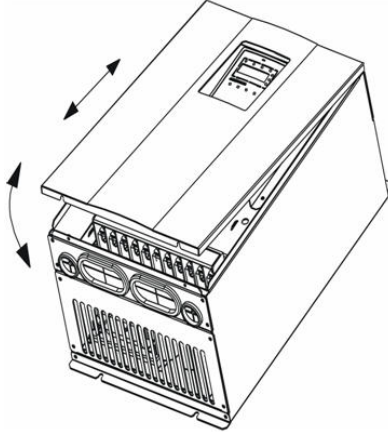

Figure D.7 Disassembly of metal plate cover

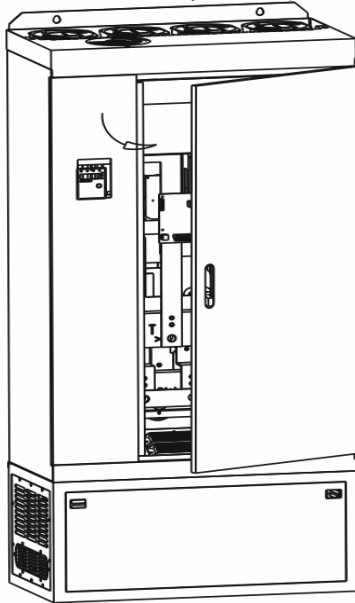

Figure D.8 Open inverter cabinet

APPENDIX E SPECIFICATIONS OF ACCESSORIES

E.1 Specifications of Breaker, Cable, Contactor and Reactor

E.1.1 Specifications of breaker, cable and contactor

Model No.	Circuit breaker (A)	Input/Output cable (mm ²) (Copper wire)	Rated current of contactor (A) (380V or 220V)
CHV190-018G-4	100	10	63
CHV190-022G-4	100	16	80
CHV190-030G-4	125	25	95
CHV190-037G-4	160	25	120
CHV190-045G-4	200	35	135
CHV190-055G-4	200	35	170
CHV190-075G-4	250	70	230
CHV190-090G-4	315	70	280
CHV190-110G-4	400	95	315
CHV190-132G-4	400	150	380
CHV190-160G-4	630	185	450
CHV190-185G-4	630	185	500
CHV190-200G-4	630	240	580
CHV190-220G-4	800	150x2	630
CHV190-250G-4	800	150x2	700
CHV190-280G-4	1000	185x2	780
CHV190-315G-4	1200	240x2	900
CHV190-350G-4	1280	240x2	960
CHV190-400G-4	1380	185x3	1035
CHV190-500G-4	1720	185x3	1290

E.1.2 Specifications of AC input/output and DC reactor

Model No.	AC input reactor		AC output reactor		DC reactor	
	Current (A)	Inductance (mH)	Current (A)	Current (A)	Inductance (mH)	Current (A)
CHV190-018G-4	50	0.35	50	0.052	40	1.3

Model No.	AC input reactor		AC output reactor		DC reactor	
	Current (A)	Inductance (mH)	Current (A)	Current (A)	Inductance (mH)	Current (A)
CHV190-022-4	60	0.28	60	0.045	50	1.08
CHV190-030-4	80	0.19	80	0.032	65	0.8
CHV190-037G-4	90	0.16	90	0.030	78	0.7
CHV190-045G-4	120	0.13	120	0.023	95	0.54
CHV190-055G-4	150	0.10	150	0.019	115	0.45
CHV190-075G-4	200	0.12	200	0.014	160	0.36
CHV190-090G-4	250	0.06	250	0.011	180	0.33
CHV190-110G-4	250	0.06	250	0.011	250	0.26
CHV190-132G-4	290	0.04	290	0.008	250	0.26
CHV190-160G-4	330	0.04	330	0.008	340	0.18
CHV190-185G-4	400	0.04	400	0.005	460	0.12
CHV190-200G-4	490	0.03	490	0.004	460	0.12
CHV190-220G-4	490	0.03	490	0.004	460	0.12
CHV190-250G-4	530	0.03	530	0.003	650	0.11
CHV190-280G-4	600	0.02	600	0.003	650	0.11
CHV190-315G-4	660	0.02	660	0.009	660	0.009
CHV190-350G-4	400*2	0.03	400*2	0.022	400*2	0.12
CHV190-400G-4	490*2	0.03	490*2	0.004	460*2	0.12
CHV190-500G-4	530*2	0.03	530*2	0.003	650*2	0.11

Notice: The CHV190-018G-4 ~ CHV190-090G-4 are using the DC reactor inside.

E.1.3 Specification of input filter and output filter

Model No	Input filter model	Output filter model
CHV190-018G-4	NFI-050	NFO-050
CHV190-022-4	NFI-050	NFO-050
CHV190-030-4	NFI-065	NFO-065
CHV190-037G-4	NFI-080	NFO-080
CHV190-045G-4	NFI-100	NFO-100
CHV190-055G-4	NFI-150	NFO-150
CHV190-075G-4	NFI-150	NFO-150
CHV190-090G-4	NFI-200	NFO-200

Model No	Input filter model	Output filter model
CHV190-110G-4	NFI-250	NFO-250
CHV190-132G-4	NFI-250	NFO-250
CHV190-160G-4	NFI-300	NFO-300
CHV190-185G-4	NFI-400	NFO-400
CHV190-200G-4	NFI-400	NFO-400
CHV190-220G-4	NFI-250	NFO-600
CHV190-250G-4	NFI-600	NFO-600
CHV190-280G-4	NFI-900	NFO-900
CHV190-315G-4	NFI-1200	NFO-1200
CHV190-350G-4	NFI-1200	NFO-1200
CHV190-400G-4	NFI-1200	NFO-1200

APPENDIX F FUNCTION PARAMETERS

Notice:

1. PE group is factory reserved, users are forbidden to access these parameters.

2. The column “Modify” determines the parameter can be modified or not.

“○” indicates that this parameter can be modified all the time.

“◎” indicates that this parameter cannot be modified during the inverter is running.

“●” indicates that this parameter is read only.

3. “Factory setting” indicates the value of each parameter while restoring the factory parameters, but those detected parameters or record values cannot be restored.

Function Code	Name	Description	Setting Range	Factory Setting	Modify
P0 Group: Basic function					
P0.00	Speed control mode	0: Sensorless vector control 1: Vector control with PG 2: V/F control	0~2	1	◎
P0.01	Run command source	0: Keypad (LED extinguished) 1: Terminal (LED flickering) 2: Communication (LED lights on) 3. Profibus communication (LED lights on)	0~3	1	◎
P0.02	Speed instruction selection	0: Keypad 1: AI1 2. AI3 3: HDI1 4: Multi-steps speed 5: UP / DOWN terminal	0~8	0	◎

Function Code	Name	Description	Setting Range	Factory Setting	Modify
		6:Modbus communication 7:Profibus communication 8:Hierarchical multi-stage speed			
P0.03	Maximum frequency	10.00~400.00Hz	10.00~400.00	50.00Hz	☉
P0.04	Keypad reference frequency	0.00Hz~P0.03	0~P0.03	50.00Hz	○
P0.05	Running direction selection	0: Forward 1: Reverse 2: Forbid reverse	0~2	0	☉
P0.06	Carrier frequency	1.0~16.0kHz	1.0~16.0	Depend on model	○
P0.07	Motor parameters autotuning	0: No action 1: Rotation autotuning 2: Static autotuning	0~2	0	☉
P0.08	Reserved	0~65535	0~65535	0	☉
P0.09	Reserved	0~65535	0~65535	0	☉
P0.10	Reserved	0~65535	0~65535	0	☉
P0.11	Application mode selection	0: Common application mode 1: Operating lever mode 2: Remote Mode 3: Hierarchical operating lever mode 4: Hierarchical remote mode 5: Electric potentiometer mode 6: Master-slave power equilibrium host mode	0~9	0	☉

Function Code	Name	Description	Setting Range	Factory Setting	Modify
		7: Master-slave power equilibrium subordinate mode 8: Master-slave speed synchronization host mode 9: Master-slave speed synchronization subordinate mode			
P0.12	Restore parameters	0: No action 1: Restore factory setting 2: Clear fault records	0~2	0	⊙
P1 Group: Speed curve					
P1.00	(Multi-segment speed) rating for 0	-100.0%~100.0%	-100.0~100.0	0.0%	⊙
P1.01	(Multi-segment speed) rating for 1	-100.0%~100.0%	-100.0~100.0	0.0%	⊙
P1.02	(Multi-segment speed) rating for 2	-100.0%~100.0%	-100.0~100.0	0.0%	⊙
P1.03	(Multi-segment speed) rating for 3	-100.0%~100.0%	-100.0~100.0	0.0%	⊙
P1.04	(Multi-segment speed) rating for 4	-100.0%~100.0%	-100.0~100.0	0.0%	⊙
P1.05	(Multi-segment speed) rating for 5	-100.0%~100.0%	-100.0~100.0	0.0%	⊙
P1.06	(Multi-segment speed) rating for 6	-100.0%~100.0%	-100.0~100.0	0.0%	⊙
P1.07	(Multi-segment speed) rating for 7	-100.0%~100.0%	-100.0~100.0	0.0%	⊙
P1.08	Acceleration /Deceleration mode	0: Linear 1:S curve	0~1	1	⊙

Function Code	Name	Description	Setting Range	Factory Setting	Modify
P1.09	Linear acceleration time	0.0~3600.0s	0.0~3600.0	20.0s	○
P1.10	Linear deceleration time	0.0~3600.0s	0.0~3600.0	20.0s	○
P1.11	Start section of acceleration S curve	0.1~50.0%	0.1~50.0	10.0%	◎
P1.12	End section of acceleration S curve	0.1~50.0%	0.1~50.0	10.0%	◎
P1.13	Start section of deceleration S curve	0.1~50.0%	0.1~50.0	10.0%	◎
P1.14	End section of deceleration S curve	0.1~50.0%	0.1~50.0	10.0%	◎
P1.15	Start frequency	0.00~10.00Hz	0.00~10.00	0.00Hz	◎
P1.16	Starting frequency keeping time	0.00~5.00s	0.00~5.00	0.00s	◎
P1.17	Jog run frequency	0.00Hz~P0.03	0.00~P0.03	5.00Hz	◎
P1.18	Jog acceleration running time	0.0~3600.0s	0.0~3600.0	20.0s	◎
P1.19	Jog deceleration running time	0.0~3600.0s	0.0~3600.0	20.0s	◎
P1.20	Motor autotuning ACC time	0.1~3600.0s	0.1~3600.0	40.0s	◎
P1.21	Motor autotuning DEC time	0.1~3600.0s	0.1~3600.0	40.0s	◎
P1.22	Slowly running frequency	0.00Hz~P0.03	0.00~P0.03	5.00Hz	◎
P1.23	Slow running ACC/DEC time	0.0~3600.0s	0.0~3600.0	20.0s	◎

Function Code	Name	Description	Setting Range	Factory Setting	Modify
P1.24	Forced deceleration time	0.0~3600.0s	0.0~3600.0	2.0s	☉
P1.25	Stop mode	0: Deceleration to stop 1: Coast to stop	0~1	0	○
P1.26	Subsidiary motor acceleration time	0.0~3600.0s	0.0~3600.0	1.0s	○
P1.27	Subsidiary motor deceleration time	0.0~3600.0s	0.0~3600.0	1.0s	○
P1.28	Reserved	0~65535	0~65535	0	☉
P1.29	Reserved	0~65535	0~65535	0	☉
P2 Group: Motor parameters					
P2.00	Inverter model	0: Asynchronous machine 1: Synchronous machine	0~1	0	☉
P2.01	Motor rated power	0.4~900.0kW	0.4~900.0	Depend on model	☉
P2.02	Motor rated frequency	0.01Hz~P0.03	0.01~P0.03	50.00Hz	☉
P2.03	Motor rated speed	1~36000rpm	1~36000	1460rpm	☉
P2.04	Motor rated voltage	0~500V	0~500	380V	☉
P2.05	Motor rated current	0.1~2000.0A	0.1~2000.0	Depend on model	☉
P2.06	Motor power factor	0.05~1.00	0.05~1.00	0.86	☉
P2.07	Motor stator resistance	0.001~65.535Ω	0.001~65.535	Depend on model	○
P2.08	Motor rotor resistance	0.001~65.535Ω	0.001~65.535	Depend on model	○
P2.09	Motor leakage inductance	0.1~6553.5mH	0.1~6553.5	Depend on model	○
P2.10	Motor mutual inductance	0.1~6553.5mH	0.1~6553.5	Depend on model	○

Function Code	Name	Description	Setting Range	Factory Setting	Modify
P2.11	Current without load	0.01~655.35A	0.01~655.35	Depend on model	○
P2.12	Magnetic pole initial position	0.00~360.00	0.00~360.00	0.00	◎
P2.13	Magnetic pole position amplitude gain	0.50~1.50	0.50~1.50	1	◎
P2.14	C-phase magnetic pole position bias	0~9999	0~9999	433	◎
P2.15	D-phase magnetic pole position bias	0~9999	0~9999	433	◎
P2.16	Motor weak magnetic coefficient	0.1~2.0	0.1~2.0	1.0	◎
P2.17	Motor minimum weak magnetic limitation	10.0~80.0%	10.0~80.0	50.0	◎
P2.18	Weak magnetic proportion	0~65535	0~65535	0	◎
P2.19	Low-frequency oscillation suppression tolerance	0~10	0~10	2	◎
P2.20	High-frequency oscillation suppression tolerance	0~10	0~10	0	◎
P2.21	Motor output maximum voltage	P2.04~550	P2.04~550	380	◎
P2.22	Reserved	0~65535	0~65535	0	◎
P3 Group: Vector control					
P3.00	ASR low-speed proportional gain	0~100	0~100	20	○

Function Code	Name	Description	Setting Range	Factory Setting	Modify
P3.01	ASR low-speed integral time	0.01~10.00s	0.01~10.00	0.50s	○
P3.02	Speed detection low-speed filter time	0.000~1.000s	0.000~1.000	0.000s	○
P3.03	Low switching frequency	0.00Hz~P3.07	0.00~P3.07	5.00Hz	○
P3.04	ASR high-speed proportional gain	0~100	0~100	25	○
P3.05	ASR low-speed integral time	0.01~10.00s	0.01~10.00	1.00	○
P3.06	Speed detection high-speed filter time	0.000~1.000s	0.000~1.000	0.000s	○
P3.07	High switching frequency	P3.03~P0.03	P3.03~P0.03	10.00Hz	○
P3.08	ACR proportional gain P	0~65535	0~65535	500	○
P3.09	ACR integral gain I	0~65535	0~65535	500	○
P3.10	Driver side slip compensation coefficients	50%~200%	50~200	100%	○
P3.11	Braking side slip compensation coefficients	50%~200%	50~200	100%	○
P3.12	Torque setting source	0: Disabled 1: Keypad 2: AI1 3: AI2 4: 485 communication 5: Profibus communication	0~7	0	◎

Function Code	Name	Description	Setting Range	Factory Setting	Modify
		6: HDI 7: Subsidiary machine inside setting			
P3.13	Keypad torque setting	-100.0%~100.0%	-100.0~100.0	50.0%	○
P3.14	Torque limit	0.0~200.0% (Rated current of inverter)	0.0~200.0	150.0%	○
P3.15	Torque limit method selection	0: Keypad 1: Profibus	0~1	0	◎
P3.16	Torque control prohibition access selection	0: Torque control ban is invalid 1: Terminal torque control prohibition is effective 2: Profibus torque control prohibition is effective 3: Both control are valid	0~3	0	◎
P3.17	Forward torque upper frequency limit	0.00~P0.03	0.00~P0.03	50.00Hz	○
P3.18	Forward torque maximum frequency limitation setting selection	0: Keypad 1: AI1 2: AI2 3: HDI 4: 485 communications 5: Profibus communication	0~5	0	◎
P3.19	Reverse torque maximum frequency limitation	0.00~P0.03	0.00~P0.03	50.00Hz	○
P3.20	Reverse torque	0: Keypad	0~5	0	◎

Function Code	Name	Description	Setting Range	Factory Setting	Modify
	maximum frequency limitation setting selection	1: AI1 2: AI2 3: HDI 4: 485 communications 5: Profibus communication			
P3.21	Proportional coefficient of high frequency current loop	0~65535	0~65535	1000	○
P3.22	Integral coefficient of high frequency current loop	0~65535	0~65535	500	○
P3.23	Torque boost	0.0~10.0	0.0~10.0	0.0%	◎
P3.24	Torque boost upper limited frequency	0.0~50.0%	0.0~50.0%	20.0%	◎
P4 Group: Encoder					
P4.00	Encoder type	0: Incremental encoder 1: SIN / COS Encoder 2: UVW encoder	0~2	0	◎
P4.01	Encoder pulse	1~65535	1~65535	1000	◎
P4.02	Encoder direction	0: Forward 1: Reverse	0~1	0	◎
P4.03	Low-speed, encoder disconnection detection time	0.1~100.0s	0.0~100.0	1.0	◎
P4.04	High-speed, encoder disconnection detection time	0.1~100.0s	0.0~100.0	1.0	◎
P4.05	Encoder reverse	0.1~100.0s	0.0~100.0	1.0	◎

Function Code	Name	Description	Setting Range	Factory Setting	Modify
	detection time				
P4.06	Position calculator conversion factor	10.0~6553.5	10.0~6553.5	10.0	⊙
P4.07	Reserved	0~65535	0~65535	0	⊙
P4.08	Reserved	0~65535	0~65535	0	⊙
P5 Group: Input terminals					
P5.00	HDI selection	0: HDI high speed pulse input. 1: HDI switch input.	0~1	0	⊙
P5.01	S4, S5 Input type selection	0: ON/OFF 1: Master-slave synchronization counter	0~1	0	⊙
P5.02	S1 terminal function	0: Invalid 1: Forward	0~40	1	⊙
P5.03	S2 terminal function	2: Reverse 3: Jog running	0~40	2	⊙
P5.04	S3 terminal function	4: Low-speed running signal	0~40	6	⊙
P5.05	S4 terminal function	5: Coast to stop 6: Reset fault	0~40	0	⊙
P5.06	S5 terminal function	7: External fault input 8: Multi-step speed	0~40	0	⊙
P5.07	HDI1 terminal function	terminal 1 (MS1) 9: Multi-step speed	0~40	0	⊙
P5.08	S7 terminal function	terminal 2 (MS2) 10: Multi-step speed	0~40	0	⊙
P5.09	S8 terminal function	terminal3 (MS3) 11: Contactor feedback	0~40	0	⊙
P5.10	S9 terminal function	signal (TB) 12: Brake feedback	0~40	0	⊙
P5.11	S10 terminal function	signal (FB) 13: Inverter enable (ENA)	0~40	0	⊙

Function Code	Name	Description	Setting Range	Factory Setting	Modify
		14: Motor switch (MEX) 15: Forced deceleration (FS) 16: Torque control prohibition 17: Motor excitation running 18: Fast stop (FS) 19: Master-slave synchronization enabled 20: Master-slave synchronization count reset 21: Light-load acceleration enable 22: Up command 23: DOWN command 24: Zero position signal 25: Classification given terminal 1 26: Classification given terminal 2 27: Classification given terminal 3 28: Classification given terminal 4 29: Classification given terminal 5 30~40: Reserved			
P5.12	Input mode selection	0~0x3FF	0~0x3FF	0x000	☉
P5.13	Input selection	0: Concrete. 1: Virtual.	0~1	0	☉

Function Code	Name	Description	Setting Range	Factory Setting	Modify
P5.14	ON-OFF filter times	1~10	1~10	5	○
P5.15	AI1 lower limit	0.00V~10.00V	0.00~10.00	0.00V	○
P5.16	AI1 lower limit corresponding setting	-100.0%~100.0%	-100.0~100.0	0.0%	○
P5.17	AI1 upper limit	0.00V~10.00V	0.00V~10.00	10.00V	○
P5.18	AI1 upper limit corresponding setting	-100.0%~100.0%	-100.0~100.0	100.0%	○
P5.19	AI1 filter time constant	0.00s~10.00s	0.00~10.00	0.10s	○
P5.20	AI2 lower limit	0.00V~10.00V	0.00~10.00	0.00V	○
P5.21	AI2 lower limit corresponding setting	-100.0%~100.0%	-100.0~100.0	0.0%	○
P5.22	AI2 upper limit	0.00V~10.00V	0.00~10.00	5.00V	○
P5.23	AI2 upper limit corresponding setting	-100.0%~100.0%	-100.0~100.0	100.0%	○
P5.24	AI2 filter time constant	0.00s~10.00s	0.00~10.00	0.10s	○
P5.25	HDI1 lower limit	0Hz~50.0kHz	0~50.0	0.0kHz	○
P5.26	HDI1 lower limit corresponding setting	-100.0%~100.0%	-100.0~100.0	0.0%	○
P5.27	HDI1 upper limit	0Hz~50.0kHz	0~50.0	50.0kHz	○
P5.28	HDI1 upper limit corresponding setting	-100.0%~100.0%	-100.0~100.0	100.0%	○
P5.29	HDI1 filter time constant	0.00s~10.00s	0.00~10.00	0.10s	○
P5.30	Reserved	0~65535	0~65535	0	◎

Function Code	Name	Description	Setting Range	Factory Setting	Modify
P5.31	Reserved	0~65535	0~65535	0	⊙
P5.32	Reserved	0~65535	0~65535	0	⊙
P5.33	Reserved	0~65535	0~65535	0	⊙
P5.34	Reserved	0~65535	0~65535	0	⊙
P5.35	Reserved	0~65535	0~65535	0	⊙
P6 Group: Output terminals					
P6.00	HDO selection	0: High-speed pulse output 1: ON-OFF output	0~1	0	⊙
P6.01	Y1 output selection	0: No output 1: Motor running	0~20	1	○
P6.02	Y2 output selection	2: Up running (UR) 3: Down running (DR)	0~20	0	○
P6.03	HDO ON-OFF output selection	4: Fault output 5: Zero speed running	0~20	0	○
P6.04	Relay 1 output selection	6: Ready 7: Brake control	0~20	4	○
P6.05	Relay 2 output selection	8: Contactor control 9: Frequency reached	0~20	5	○
P6.06	Relay 3 output selection	10: FDT reached 11: Motor running1 (LR1) 12: Closing output (FO) 13: Motor switching output 14: Motor excitation 15: Motor excitation completion output 16: Sling loose alarm output 17: High-speed signal output 18: Motor over temperature alarm	0~20	0	○

Function Code	Name	Description	Setting Range	Factory Setting	Modify
		output 19~20: Reserved			
P6.07	AO1 function selection	0: Running frequency 1: Reference frequency	0~14	0	<input type="radio"/>
P6.08	AO2 function selection	2: Slope given frequency 3: Reserved	0~14	1	<input type="radio"/>
P6.09	HDO function selection	4: Output current 5: Output voltage 6: Output power 7: Running torque 8: Output torque 9: AI1 10: AI2 11: HDI1 12~14: Reserved	0~14	0	<input type="radio"/>
P6.10	AO1 lower limit	0.0%~100.0%	0.0~100.0	0.0%	<input type="radio"/>
P6.11	AO1 lower limit corresponding output	0.00V ~10.00V	0.00~10.00	0.00V	<input type="radio"/>
P6.12	AO1 upper limit	0.0%~100.0%	0.0~100.0	100.0%	<input type="radio"/>
P6.13	AO1 upper limit corresponding output	0.00V ~10.00V	0.00~10.00	10.00V	<input type="radio"/>
P6.14	AO2 lower limit	0.0%~100.0%	0.0~100.0	0.0%	<input type="radio"/>
P6.15	AO2 lower limit corresponding output	0.00V ~10.00V	0.00~10.00	0.00V	<input type="radio"/>
P6.16	AO2 upper limit	0.0%~100.0%	0.0~100.0	100.0%	<input type="radio"/>
P6.17	AO2 upper limit corresponding output	0.00V ~10.00V	0.00~10.00	10.00V	<input type="radio"/>
P6.18	HDO lower limit	0.0%~100.0%	0.0~100.0	0.0%	<input type="radio"/>
P6.19	HDO lower limit	0.0 ~ 50.0kHz	0.0~50.0	0.0kHz	<input type="radio"/>

Function Code	Name	Description	Setting Range	Factory Setting	Modify
	corresponding output				
P6.20	HDO upper limit	0.0%~100.0%	0.0~100.0	100.0%	○
P6.21	HDO upper limit corresponding output	0.0 ~ 50.0kHz	0.0~50.0	50.0kHz	○
P6.22	FDT level	0.00~ P0.03	0.00~ P0.03	50.00Hz	○
P6.23	FDT lag	0.0~100.0%	0.0~100.0	5.0%	○
P6.24	Frequency arrive detecting range	0.0~100.0%	0.0~100.0	0.0%	○
P6.25	Reserved	0~65535	0~65535	0	◎
P6.26	Reserved	0~65535	0~65535	0	◎
P7 Group: Display interface					
P7.00	User password	0~65535	0~65535	0	○
P7.01	Reserved	0~1	0~1	0	○
P7.02	Reserved	0~1	0~1	0	◎
P7.03	QUICK/JOG function selection	1: Jog 2: FDW/REV switching	0~1	0	◎
P7.04	STOP/RST function selection	0: Valid when keypad control (P0.01=0) 1: Valid when keypad or terminal control (P0.01=0 or 1) 2: Valid when keypad or communication control (P0.01=0 or 2) 3: Always valid	0~3	0	○
P7.05	Motor temperature	-200.0~200.0℃	-200.0~200.0	0.0℃	●
P7.06	Running status display selection	1. Output frequency 2. Reference frequency 3. DC bus voltage 4. Output voltage 5. Output current	0~0xFFFF	0x0003	○

Function Code	Name	Description	Setting Range	Factory Setting	Modify
		Other parameters display is determined by 16 bit binary digit BIT0: Rotation speed BIT1: Output power BIT2: Output torque BIT3: Input terminal status BIT4: Output terminal status BIT5: AI1 BIT6: AI2 BIT7: HDI frequency BIT8: Torque Compensation BIT9: Magnetic pole position BIT10: Reserved BIT11: Reserved BIT12: Reserved BIT13: Reserved BIT14: Reserved BIT15: Reserved			
P7.07	Stop status display selection	BIT0: Reference frequency BIT1: Fault code BIT2: DC bus voltage BIT3: Input terminal status BIT4: Output terminal status BIT5: Motor pole pairs	0x0001~0xFF FF	0x00FF	○

Function Code	Name	Description	Setting Range	Factory Setting	Modify
		BIT6: AI1 BIT7: AI2 BIT8: HDI frequency BIT9: Reserved BIT10: Reserved BIT11: Reserved BIT12: Reserved BIT13: Reserved BIT14: Reserved BIT15: Reserved			
P7.08	Rectifier module temperature	0~150.0℃			●
P7.09	IGBT module temperature	0~150.0℃			●
P7.10	MCU software version	Factory setting			●
P7.11	DSP software version	Factory setting			●
P7.12	Accumulated running time	0~65535h			●
P7.13	Third latest fault type	0: Not fault 1: IGBT Ph-U fault			●
P7.14	Second latest fault type	(OUT1) 2: IGBT Ph-V fault			●
P7.15	Latest fault type	(OUT2) 3: IGBT Ph-W fault (OUT3) 4: Over-current when Acceleration (OC1) 5: Over-current when Deceleration (OC2) 6: Over-current when constant speed running			●

Function Code	Name	Description	Setting Range	Factory Setting	Modify
		(OC3) 7: Over-voltage when Acceleration (OV1) 8: Over-voltage when Deceleration (OV2) 9: Over-voltage when constant speed running (OV3) 10: DC bus Under-voltage (UV) 11: Motor overload (OL1) 12: Inverter overload (OL2) 13: Input phase failure (SPI) 14: Output phase failure (SPO) 15: Rectify overheat (OH1) 16: IGBT overheat (OH2) 17: External fault (EF) 18: Communication fault (CE) 19: Current detection fault (ITE) 20: Autotuning fault (TE) 21: Encoder fault (PCE) 22: Encoder reverse fault (PCDE) 23: System fault (OPSE) 24: EEPROM fault (EEP)			

Function Code	Name	Description	Setting Range	Factory Setting	Modify
		25: Magnetic pole position failure (PPCE) 26: Brake unit fault (bCE) 27: Trial time reached (-END-) 28: LCD disconnected (LCD-E) 29: Brake feedback fault (FAE) 30: Contactor feedback fault (TbE) 31: Torque verification fault (TPF) 32: Motor speed fault (OFE) 33: Torque Monitoring fault (TFT) 34: Profibus communication fault (PCF) 35: Master-slave speed synchronization fault (ELS) 36: Multi-segment speed rating fault (STEP) 37: Operating lever fault (STC) 38: Earth connection fault (ETH) 39: CAN bus communication fault (CA)			

Function Code	Name	Description	Setting Range	Factory Setting	Modify
		40: Motor over-temperature fault (OH3) 41~50: Reserved			
P7.16	Output frequency at current fault				●
P7.17	Output current at current fault				●
P7.18	DC bus voltage at current fault				●
P7.19	Input terminal status at current fault				●
P7.20	Output terminal status at current fault				●
P7.21	Inverter rated power				●
P7.22	Inverter rated current				●
P8 Group: Enhanced function					
P8.00	Pre-torque signal input selection	0: No function 1: AI1 2: AI2 3: Profibus communication given 4: The internal dynamic given	0~4	0	◎
P8.01	Pre-torque offset	-100.0~100.0%	-100.0~100.0	0.0%	○
P8.02	Drive gain	0.000~7.000	0.000~7.000	1.000	○
P8.03	Brake gain	0.000~7.000	0.000~7.000	1.000	○
P8.04	Brake, contactor control selection	0: Invalid 1: Brake valid, contactor	0~3	0	◎

Function Code	Name	Description	Setting Range	Factory Setting	Modify
		invalid 2: Brake invalid, contactor valid 3: Brake and contactor valid			
P8.05	Delay time of brake closed	0.00~5.00s	0.00~5.00	0.00s	☉
P8.06	Delay time of brake open	0.00~5.00s	0.00~5.00	0.00s	☉
P8.07	Brake feedback inspecting interval	0.1~5.0S	0.1~5.0	2.0s	☉
P8.08	Contactor feedback inspecting interval	0.1~5.0s	0.1~5.0	2.0s	☉
P8.09	Brake frequency when parking	0.00~5.00Hz	0.00~5.00	0.00Hz	☉
P8.10	DC braking current before start	0.0~120.0%	0.0~120.0	0.0%	☉
P8.11	DC braking time before start	0.0~50.0s	0.0~50.0	0.0s	☉
P8.12	Starting frequency of DC braking	0.00~P0.03	0.00~P0.03	0.00Hz	○
P8.13	Waiting time before DC braking	0.0~50.0s	0.0~50.0	0.0s	○
P8.14	DC braking current	0.0~120.0%	0.0~120.0	0.0%	○
P8.15	DC braking time	0.0~50.0s	0.0~50.0	0.0s	○
P8.16	Inverter stop delay time	0.00~5.00s	0.00~5.00	0.00s	☉
P8.17	Auto reset times	0~10	0~10	0	○
P8.18	Fault relay action	0: Disabled 1: Enabled	0~1	1	○

Function Code	Name	Description	Setting Range	Factory Setting	Modify
P8.19	Reset interval	0.1~100.0s	0.1~100.0	1.0s	○
P8.20	Brake threshold voltage	320.0~750.0V	320.0~750.0	700.0V	○
P8.21	Two-phase/three-phase modulation	0: Two-phase modulation 1: Three-phase modulation	0~1	0	◎
P8.22	Electrical excitation enable	0: Disabled 1: Enabled	0~1	0	◎
P8.23	Motor excitation time	0.004~5.000s	0.004~5.000	0.010s	◎
P8.24	Torque monitoring selection	0: Invalid 1: Valid	0~1	0	◎
P8.25	Speed deviation limit of torque fault	0.0~100.0%	0.0~100.0	10.0%	◎
P8.26	Delay time of torque fault	0~60000ms	0~60000	1000ms	◎
P8.27	Blocking factor of acceleration deviation when ACC/DEC	110.0~500.0%	110.0~500.0	150.0%	◎
P8.28	Output torque of electric brake	0.0~200.0%	0.0~200.0	180.0%	○
P8.29	Acceleration time of braking torque	0.001~9.000s	0.001~9.000	1.000s	○
P8.30	Braking torque ending frequency	0.00~30.00Hz	0.00~30.00	0.10Hz	○
P8.31	Applying time of electric brake to fast stop	0.00~20.00s	0.00~20.00	2.00s	○
P8.32	Fast stop mode	0: The electric braking only 1: The electric brake and	0~2	0	◎

Function Code	Name	Description	Setting Range	Factory Setting	Modify
		the mechanical brake 2: The mechanical brake only			
P8.33	Torque verification enable	0: Disabled 1: Enabled	0~1	0	☉
P8.34	Keypad setting of torque verification	0.0~100.0%	0.0~100.0	10.0%	☉
P8.35	Torque verification fault delay time	0.0~10.0 s	0.0~10.0	0.5s	☉
P8.36	Light-load speeding up enable	0: Invalid 1: Valid	0~1	0	☉
P8.37	Speeding up command selection	0: Automatic 1: Terminals 2: Communication	0~2	1	☉
P8.38	Frequency fluctuation coefficient	0~100	0~100	10	☉
P8.39	Speed turning point of constant power	0.0~200.0%	0.0~200.0	100.0%	☉
P8.40	Filtering time factor of load torque signal	0.0~10.0s	0.0~10.0	0.2s	☉
P8.41	Torque autotuning selection without load	0: Self-tuning deactive 1: Self-tuning active	0~1	0	☉
P8.42	Consumed torque by empty hook rising	0.0~150.0%	0.0~150.0		●
P8.43	Consumed torque by empty hook descent	0.0~150.0%	0.0~150.0		●

Function Code	Name	Description	Setting Range	Factory Setting	Modify
P8.44	Output torque limit of rising up	0.0~150.0%	0~150.0	100.0%	☉
P8.45	Output torque limit of descent	0.0~150.0%	0~150.0	75.0%	☉
P8.46	Sling loosening torque threshold	1.0~100.0%	1.0~100.0	3.0%	☉
P8.47	Sling loosening alarm output enable in falling	0: Prohibition 1: Output alarm signal 2: Output alarm, shutdown and brake	0~2	0	☉
P8.48	Operating lever zero position detection enable	0: Disabled 1: Enabled	0~1	0	☉
P8.49	Operating lever zero position delay time	0.0~60.0s	0.0~60.0	0.3s	☉
P8.50	Over-current stall protection	0: Disabled 1: Enabled	0~1	1	☉
P8.51	Coefficient of over-current stall	100~200%	100~200	150%	☉
P8.52	Frequency decreasing rate of over-current	0.00~50.00Hz/s	0.00~50.00	10.00Hz/s	☉
P8.53	Reserved	0~65535	0~65535	0	☉
P8.54	Reserved	0~65535	0~65535	0	☉
P8.55	Reserved	0~65535	0~65535	0	☉
P8.56	Acceleration proportional coefficient	0.00~5.00	0.00~5.00	0.005	○
P8.57	Acceleration integral coefficient	0.01~20.00	0.01~20.00	1.00s	○
P8.58	Acceleration integral result limit	0.0~10.0	0.0~10.0	2.0%	○

Function Code	Name	Description	Setting Range	Factory Setting	Modify
P8.59	Acceleration differential coefficient	0.01~20.00	0.01~20.00	0.00s	<input type="radio"/>
P8.60	PID voltage threshold of adjuster	65.0~P8.54	65.0~P8.54	70%	<input type="radio"/>
P8.61	Adjuster operational ways	0 .Dissipated by PID. 1. Converted to by current PID adjuster output value (Valid when slave mode is valid only).	0~1	0	<input type="radio"/>
P8.62	Integral coefficient of adjuster PID	0.01~20.00	0.01~20.00	3.00s	<input type="radio"/>
P8.63	Differential coefficient of adjuster PID	0.00~20.00	0.00~20.00	0.00s	<input type="radio"/>
P9 Group: Protection function					
P9.00	Input phase-failure protection	0: Disabled 1: Enabled	0~1	1	<input type="radio"/>
P9.01	Output phase-failure protection	0: Disabled 1: Enabled	0~1	1	<input type="radio"/>
P9.02	Motor overload protection	0: Disabled 1: Normal motor 2: Variable frequency motor	0~2	2	<input checked="" type="radio"/>
P9.03	Motor overload protection current	20.0%~120.0%	20.0~120.0	100.0%	<input type="radio"/>
P9.04	Overload pre-warning threshold	20.0%~150.0%	20.0~150.0	130.0%	<input type="radio"/>
P9.05	Overload	0: Always detect	0~3	0	<input checked="" type="radio"/>

Function Code	Name	Description	Setting Range	Factory Setting	Modify
	pre-warning selection	relative to motor rated current 1: Detect while constant speed relative to motor rated current 2: Always detect relative to inverter rated current 3: Detect while constant speed relative to inverter rated current			
P9.06	Overload pre-warning delay time	0.0~30.0s	0.0~30.0	5.0s	○
P9.07	Motor overspeed protection	0: Invalid 1: Valid	0~1	0	◎
P9.08	Overspeed protection point of motor 1	100.0~200.0%	100.0~200.0	110.0%	◎
P9.09	Overspeed protection point of motor 2	100.0~200.0%	100.0~200.0	110.0%	◎
P9.10	Motor over-temperature protection	0: Disabled 1: Enabled	0~1	0	◎
P9.11	Type of motor temperature sensor and signal source setting	0: PT100 1: PT1000	0~1	0	◎
P9.12	Temperature adjusting bias	-80.0~80.0℃	-80.0~80.0	0.0℃	◎
P9.13	Temperature correct factor	50.0~150.0%	50.0~150.0	100.0%	◎

Function Code	Name	Description	Setting Range	Factory Setting	Modify
P9.14	The motor 1 over-temperature protection point	0~150.0℃	0~150.0	100.0℃	⊙
P9.15	The motor 1 over-temperature warning point	20.0%~100.0%	20.0~100.0	90.0%	⊙
P9.16	The motor 2 over-temperature protection point	0~150.0℃	0~150.0	100.0℃	⊙
P9.17	The motor 2 over-temperature warning point	20.0%~100.0%	20.0~100.0	90.0%	⊙
P9.18	Motor temperature compensation enable	0: Disabled 1: Enabled	0~1	0	⊙
P9.19	Reserved	0~65535	0~65535	0	⊙
P9.20	Reserved	0~65535	0~65535	0	⊙
P9.21	Reserved	0~65535	0~65535	0	⊙
P9.22	Reserved	0~65535	0~65535	0	⊙
PA Group: Serial communication					
PA.00	Local communication address	1~247 0: Broadcast address	1~247	1	○
PA.01	Communication baud rate selection	0: 1200BPS 1: 2400BPS 2: 4800BPS 3: 9600BPS 4: 19200BPS 5: 38400BPS	0~5	4	○
PA.02	Data format	0: No parity (8,N,2) for RTU 1: Even parity (8,E,1) for RTU	0~8	1	○

Function Code	Name	Description	Setting Range	Factory Setting	Modify
		2: Odd parity (8,O,1) for RTU 3: No parity (8,N,2) for ASCII 4: Even parity (8,E,1) for ASCII 5: Odd parity (8,O,1) for ASCII 6: No parity (7,N,2) for ASCII 7: Even parity (7,E,1) for ASCII 8: Odd parity (7,O,1) for ASCII			
PA.03	Communication reply delay	0~20ms	0~20	0ms	○
PA.04	Communication timeout fault time	0.0 (invalid) 0.1~100.0s	0.0~100.0	0.0s	○
PA.05	Communication reply enable	0: Communication reply enabled 1: Communication reply disabled	0~1	0	○
PA.06	Transmission error handling	0: Report fault and coast to stop 1: Do not report fault and continue running 2: Do not report fault and stop according to setting 3: Do not report fault and stop according to setting	0~3	1	◎
PA.07	485 communication protocol	0: Modbus protocol 1: Master-slave control protocol	0~1	0	◎

Function Code	Name	Description	Setting Range	Factory Setting	Modify
PA.08	Ethernet communication speed setting	0: 10 M full-duplex 1: 10 M half-duplex 2: 100 M full-duplex 3: 100 M half-duplex 4: Adaptive	0~4	0	⊙
PA.09	IP address 1	0~255	0~255	192	⊙
PA.10	IP address 2	0~255	0~255	168	⊙
PA.11	IP address 3	0~255	0~255	0	⊙
PA.12	IP address 4	0~255	0~255	1	⊙
PA.13	Subnet mas 1	0~255	0~255	255	⊙
PA.14	Subnet mas 2	0~255	0~255	255	⊙
PA.15	Subnet mas 3	0~255	0~255	254	⊙
PA.16	Subnet mas 4	0~255	0~255	0	⊙
PA.17	Reserved	0~255	0~255	0	⊙
PA.18	Reserved	0~255	0~255	0	⊙
PA.19	Reserved	0~255	0~255	0	⊙
PA.20	Reserved	0~255	0~255	0	⊙
PA.21	Reserved	0~255	0~255	0	⊙
PA.22	CAN address	0~127	0~127	1	⊙
PA.23	CAN baud rate settings	0: 20K BPS 1: 50K BPS 2: 100K BPS 3: 250K BPS 4: 500K BPS 5: 1M BPS	0~5	4	⊙
PA.24	CAN communication timeout delay	0.0 (invalid) 0.1~100.0s	0.0~100.0	0	⊙
Pb Group: Master-slave control					
Pb.00	Master-slave control mode selection	0: Stand-alone mode 1: Power balance mode 2: Speed synchronous mode	0~2	0	⊙

Function Code	Name	Description	Setting Range	Factory Setting	Modify
Pb.01	Master-slave mode setting	0: Master-slave mode is invalid 1: This is the master 2: This is the slave 3: Master or slave is set by Profibus	0~3	0	
Pb.02	Reference signal source from the master to the slave	0: Master output torque 1: Master output current 2: Pulse counter of master encoder	0~2	0	○
Pb.03	The interval of master sending data to slave	0~10000ms	0~10000	4ms	○
Pb.04	Master-slave communication channel selection	0: Prohibited communications 1: CAN communication 2: 485	0~2	0	○
Pb.05	The slave control source	0: Master communications control 1: According to P0.01 setting.	0~1	0	○
Pb.06	The slave reference frequency source	0: From the master communications 1: Selection through P0.02	0~1	0	○
Pb.07	The gain from the slave reference frequency source	0.01~100.00	0.01~100.00	1.00	○
Pb.08	The slave reference signal source	0: Master communications 1: AI1 2: AI2 3: HDI1	0~3	0	○

Function Code	Name	Description	Setting Range	Factory Setting	Modify
Pb.09	The gain of the slave reference signal source	0.01~100.00	0.01~100.00	1.00	○
Pb.10	Filtering time of the slave reference signal	0.0~3.0s	0.0~3.0	0.0s	◎
Pb.11	PID proportional coefficient 1	0.000~10.000	0.00~10.000	0.005	○
Pb.12	PID integral time 1	0.01~80.00s	0.01~80.00	8.00s	○
Pb.13	PID switching low point	0.00Hz~Pb.16	0.00~Pb.16	5.00Hz	○
Pb.14	PID proportional coefficient 2	0.00~10.000	0.00~10.000	0.010	○
Pb.15	PID integral time 2	0.01~80.00s	0.01~80.00	10.00s	○
Pb.16	PID switching high point	Pb.13~P0.03	Pb.13~P0.03	10.00Hz	○
Pb.17	PID differential time	0.00~10.00s	0.00~10.00	0.00s	○
Pb.18	PID output filter time	0.00~10.00s	0.00~10.00	0.00s	○
Pb.19	Integral result of limiting	0.0~100.0%	0.0~100.0	100.0%	○
Pb.20	The results of integration	-100.0~100.0%	-100.0~100.0		●
Pb.21	Bias limit	0.0~80.0%	0.0~80.0	0.0%	○
Pb.22	PID regulation characteristics	0: Positive 1: Negative	0~1	0	○
Pb.23	PID mode selection	0: Take proportional-plus-integral result as the synchronization coefficient 1: Take proportional	0~2	2	○

Function Code	Name	Description	Setting Range	Factory Setting	Modify
		coefficient of P as error correction, I as integral synchronous coefficient 2: Take proportional coefficient P and Integral coefficient I as the error correction 3: Only use the proportion			
Pb.24	PID integration of lower synchronized speed limit	0.0~100.0%	0.0~100.0	0.0%	<input type="radio"/>
Pb.25	PID enabled	0: Disabled 1: Enabled	0~1	0	<input type="radio"/>
Pb.26	Numerator of synchronized variable speed ratio	1 ~32000	1 ~32000	1000	<input type="radio"/>
Pb.27	Nominator of synchronized variable speed ratio	1 ~32000	1 ~32000	1000	<input type="radio"/>
Pb.28	limit of synchronous speed position fault	0~50000	0~50000	1000	<input type="radio"/>
Pb.29	Speed synchronous position deviation adjustment dead zone	0~20000	0~20000	50	<input type="radio"/>
Pb.30	The amplitude	0.0~100.0%	0.0~100.0	5.0%	<input type="radio"/>

Function Code	Name	Description	Setting Range	Factory Setting	Modify
	limiting of speed synchronous regulator				
Pb.31	the minimum speed of synchronous output enable	0.0~100.0%	0.0~100.0	2.0%	⊙
Pb.32	Reset source of speed synchronous counter	0: Automatic 1: Terminals	0~1	0	⊙
Pb.33	Reset terminal polarity of synchronous speed counter	0: Rising edge 1: Falling edge	0~1	0	⊙
Pb.34	Pulse counter source of synchronous speed	0: External terminal S4, S5 1: Internal encoder pulse counting	0~1	1	⊙
Pb.35	Reserved	0~65535	0~65535	0	⊙
PC Group: Motor parameters 1					
PC.00	Speed control mode 1	0: Sensorless vector control 1: Vector control with PG 2: V/F control	0~2	1	⊙
PC.01	Maximum frequency 1	10.00~400.00Hz	10.00~400.00	50.00Hz	⊙
PC.02	Motor rated speed power 1	0.4~900.0kW	0.4~900.0	Depend on model	⊙
PC.03	Motor rated speed frequency 1	0.01Hz~400.00Hz	0.01~400.00	50.00Hz	⊙
PC.04	Motor rated speed1	1~36000rpm	1~36000	1460rpm	⊙

Function Code	Name	Description	Setting Range	Factory Setting	Modify
PC.05	Motor rated speed voltage 1	1~480V	1~480	380V	☉
PC.06	Motor basic speed current 1	0.1~2000.0A	0.1~2000.0	Depend on model	☉
PC.07	Motor rated speed power factor 1	0.05~1.00	0.05~1.00	0.86	☉
PC.08	Motor stator resistance 1	0.001~65.535Ω	0.001~65.535	Depend on model	○
PC.09	Motor rotor resistance 1	0.001~65.535Ω	0.001~65.535	Depend on model	○
PC.10	Motor leakage inductance 1	0.1~6553.5mH	0.1~6553.5	Depend on model	○
PC.11	Motor mutual inductance 1	0.1~6553.5mH	0.1~6553.5	Depend on model	○
PC.12	Current without load 1	0.01~655.35A	0.01~655.35	Depend on model	○
PC.13	Acceleration time 1	0.0~3600.0s	0.0~3600.0	20.0s	○
PC.14	Deceleration time 1	0.0~3600.0s	0.0~3600.0	20.0s	○
PC.15	Start section of acceleration S curve 1	0.1~50.0%	0.1~50.0	10.0%	☉
PC.16	End section of acceleration S curve 1	0.1~50.0%	0.1~50.0	10.0%	☉
PC.17	Start section of deceleration S curve 1	0.1~50.0%	0.1~50.0	10.0%	☉
PC.18	End section of deceleration S curve 1	0.1~50.0%	0.0~50.0	10.0%	☉
PC.19	Encoder type	0: Increment encoder	0~2	0	☉

Function Code	Name	Description	Setting Range	Factory Setting	Modify
	selection	1: SIN/COS encoder 2: UVM encoder			
PC.20	Encoder pulse counting 1	1~65535	1~65535	1000	☉
PC.21	Encoder direction 1	0: Forward 1: Reverse	0~1	0	☉
PC.22	Carrier frequency 1	1.0~16.0kHz	1.0~16.0	Depend on model	○
PC.23	ASR proportional gain K_p1	0~100	0~100	20	○
PC.24	ASR integral time K_i1	0.01~10.00s	0.01~10.00	0.50s	○
PC.25	Low speed detecting filter time 1	0.000~1.000s	0.000~1.000	0.000s	○
PC.26	ASR switching point 1	0.00Hz~PC.30	0.00~PC.30	5.00Hz	○
PC.27	ASR proportional gain K_p1	0~100	0~100	25	○
PC.28	ASR integral time K_i2	0.01~10.00s	0.01~10.00	1.00	○
PC.29	High speed detecting filter time 1	0.000~1.000s	0.000~1.000	0.000s	○
PC.30	ASR switching point 2	PC.26~P0.03	PC.26~P0.03	10.00Hz	○
PC.31	ACR proportional gain P1	0~65535	0~65535	500	○
PC.32	ACR integral gain I1	0~65535	0~65535	500	○
PC.33	Motor weak magnetic 1	0.1~2.0	0.1~2.0	1.0	☉
PC.34	Motor minimum	10.0~80.0%	10.0~80.0	50.0%	☉

Function Code	Name	Description	Setting Range	Factory Setting	Modify
	weak magnetic 1				
PC.35	The proportion of weak magnetic 1	0~65535	0~65535	0	⊙
PC.36	Low-frequency threshold of restraining oscillation 1	0~10	0~10	2	⊙
PC.37	High-frequency threshold of restraining oscillation 1	0~10	0~10	0	⊙
PC.38	Maximum motor output voltage 1	PC.05~550V	PC.05~550	380V	⊙
PC.39	HF-ACR proportional gain P1	0~65535	0~65535	1000	⊙
PC.40	HF-ACR integral gain I1	0~65535	0~65535	1000	○
PC.41	Slip compensation coefficient 1 of drive side	50~200	50~200	100%	○
PC.42	Slip compensation coefficient 1 of braking side	50~200	50~200	100%	○
PC.43	Torque upper limit current value 1	0.0~200	0.0~200	110%	⊙
PC.44	Motor overspeed point 1	0~200	0~200	110%	⊙
PC.45	Motor overtemperature 1	0~1	0~1	0	⊙
PC.46	Motor overtemperature threshold 1	0.0~60.0	0.0~60.0	40.0℃	⊙

Function Code	Name	Description	Setting Range	Factory Setting	Modify
PC.47	Motor overtemperature prewarning threshold 1	20.0~100.0	20.0~100.0	90%	☉
PC.48	Motor temperature compensation enable 1	0~1	0~1	0	☉
PC.49	Motor temperature compensation initial threshold 1	0.0~60.0	0.0~60.0	40.0℃	○
PC.50	Motor temperature compensation coefficient 1	0.0~200.0	0.0~200.0	100	○
PC.51	Reserved	0~65535	0~65535	0	☉
PC.52	Reserved	0~65535	0~65535	0	☉
PC.53	Motor type 1	0~1	0~1	0	☉
PC.54	Magnetic pole initial position 1	0.00~360.00	0.00~360.00	0	☉
PC.55	Magnetic pole position amplitude gain 1	0.50~1.50	0.50~1.50	1	☉
PC.56	C phase magnetic pole position bias 1	0~9999	0~9999	433	☉
PC.57	D phase magnetic pole position bias 1	0~9999	0~9999	433	☉
Pd Group: Profibus communication					
Pd.00	Module type	1: Profibus	1	00001	●
Pd.01	Module address	0~99	0~99	2	☉
Pd.02	PZD2 receiving	0: Invalid	0~20	1	○
Pd.03	PZD3 receiving	1: Speed reference	0~20	2	○

Function Code	Name	Description	Setting Range	Factory Setting	Modify
Pd.04	PZD4 receiving	2: Traction reference	0~20	3	○
Pd.05	PZD5 receiving	3: The maximum current reference	0~20	0	○
Pd.06	PZD6 receiving		0~20	0	○
Pd.07	PZD7 receiving	4: The starting pre-torque	0~20	0	○
Pd.08	PZD8 receiving		0~20	0	○
Pd.09	PZD9 receiving	compensation value	0~20	0	○
Pd.10	PZD10 receiving	5: Torque upper limit frequency	0~20	0	○
Pd.11	PZD11 receiving		0~20	0	○
Pd.12	PZD12 receiving	6: Master-slave mode selection 7~20: Reserved	0~20	0	○
Pd.13	PZD2 sending	0: Invalid	0~30	9	○
Pd.14	PZD3 sending	1: Running speed	0~30	10	○
Pd.15	PZD4 sending	2: Reference speed	0~30	11	○
Pd.16	PZD5 sending	3: DC bus voltage	0~30	6	○
Pd.17	PZD6 sending	4: Output voltage	0~30	7	○
Pd.18	PZD7 sending	5: Output current	0~30	5	○
Pd.19	PZD8 sending	6: Output torque	0~30	0	○
Pd.20	PZD9 sending	7: Output power	0~30	0	○
Pd.21	PZD10 sending	8: Running frequency	0~30	0	○
Pd.22	PZD11 sending	9: Function code	0~30	0	○
Pd.23	PZD12 sending	10: Reserved 11: PG Card position 12: Input terminal status 13: Output terminal status 14: Torque compensation 15: Motor rated torque 16: Given frequency of the slope 17: Pd.24 18~30: Reserved	0~30	0	○

Function Code	Name	Description	Setting Range	Factory Setting	Modify
Pd.24	Temporary variable of PZD sending	0~65535	0~65535	0	<input type="radio"/>
Pd.25	The timeout of dp communication fault	0.0 (invalid), 0.1~100.0s	0.0~100.0	0.0s	<input type="radio"/>
PE Group: Factory setting					
PE.00	Factory password	0~65535	0~65535	*****	<input checked="" type="radio"/>
PF Group: Motor parameters 2					
PF.00	Speed control mode 2	0: Sensorless vector control 1: Vector control with PG 2: V/F control	0~2	1	<input checked="" type="radio"/>
PF.01	Maximum frequency 2	10.00~400.00Hz	10.00~400.00	50.00Hz	<input checked="" type="radio"/>
PF.02	Motor rated speed power 2	0.4~900.0kW	0.4~900.0	Depend on model	<input checked="" type="radio"/>
PF.03	Motor rated speed frequency 2	0.01Hz~400.00Hz	0.01~400.00	50.00Hz	<input checked="" type="radio"/>
PF.04	Motor rated speed2	1~36000rpm	1~36000	1460rpm	<input checked="" type="radio"/>
PF.05	Motor rated speed voltage 2	1~480V	1~480	380V	<input checked="" type="radio"/>
PF.06	Motor basic speed current 2	0.1~2000.0A	0.1~2000.0	Depend on model	<input checked="" type="radio"/>
PF.07	Motor rated speed power factor 2	0.05~1.00	0.05~1.00	0.86	<input checked="" type="radio"/>
PF.08	Motor stator resistance 2	0.001~65.535Ω	0.001~65.535	Depend on model	<input type="radio"/>
PF.09	Motor rotor resistance 2	0.001~65.535Ω	0.001~65.535	Depend on model	<input type="radio"/>
PF.10	Motor leakage inductance 2	0.1~6553.5mH	0.1~6553.5	Depend on model	<input type="radio"/>

Function Code	Name	Description	Setting Range	Factory Setting	Modify
PF.11	Motor mutual inductance 2	0.1~6553.5mH	0.1~6553.5	Depend on model	<input type="radio"/>
PF.12	Current without load 2	0.01~655.35A	0.01~655.35	Depend on model	<input type="radio"/>
PF.13	Acceleration time 2	0.0~3600.0s	0.0~3600.0	20.0s	<input type="radio"/>
PF.14	Deceleration time 2	0.0~3600.0s	0.0~3600.0	20.0s	<input type="radio"/>
PF.15	Start section of acceleration S curve 2	0.1~50.0%	0.1~50.0	10.0%	<input checked="" type="radio"/>
PF.16	End section of acceleration S curve 2	0.1~50.0%	0.1~50.0	10.0%	<input checked="" type="radio"/>
PF.17	Start section of deceleration S curve 2	0.1~50.0%	0.1~50.0	10.0%	<input checked="" type="radio"/>
PF.18	End section of deceleration S curve 2	0.1~50.0%	0.0~50.0	10.0%	<input checked="" type="radio"/>
PF.19	Encoder type selection	0: Increment encoder 1: SIN/COS encoder 2: UVM encoder	0~2	0	<input checked="" type="radio"/>
PF.20	Encoder pulse counting 2	1~65535	1~65535	1000	<input checked="" type="radio"/>
PF.21	Encoder direction 2	0: Forward 1: Reverse	0~1	0	<input checked="" type="radio"/>
PF.22	Carrier frequency 2	1.0~16.0kHz	1.0~16.0	Depend on model	<input type="radio"/>
PF.23	ASR proportional gain K_p2	0~100	0~100	20	<input type="radio"/>
PF.24	ASR integral time K_i2	0.01~10.00s	0.01~10.00	0.50s	<input type="radio"/>

Function Code	Name	Description	Setting Range	Factory Setting	Modify
PF.25	Low speed detecting filter time 2	0.000~1.000s	0.000~1.000	0.000s	○
PF.26	ASR switching point 2	0.00Hz~PF.30	0.00~PF.30	5.00Hz	○
PF.27	ASR proportional gain K_p2	0~100	0~100	25	○
PF.28	ASR integral time K_i2	0.01~10.00s	0.01~10.00	1.00	○
PF.29	High speed detecting filter time 2	0.000~1.000s	0.000~1.000	0.000s	○
PF.30	ASR switching point 2	PF.26~P0.03	PF.26~P0.03	10.00Hz	○
PF.31	ACR proportional gain P2	0~65535	0~65535	500	○
PF.32	ACR integral gain I2	0~65535	0~65535	500	○
PF.33	Motor weak magnetic 2	0.1~2.0	0.1~2.0	1.0	◎
PF.34	Motor minimum weak magnetic 2	10.0~80.0%	10.0~80.0	50.0%	◎
PF.35	The proportion of weak magnetic 2	0-65535	0-65535	0	◎
PF.36	Low-frequency threshold of restraining oscillation 2	0~10	0~10	2	◎
PF.37	High-frequency threshold of restraining oscillation 2	0~10	0~10	0	◎
PF.38	Maximum motor	PF.05~550V	PF.05~550	380V	◎

Function Code	Name	Description	Setting Range	Factory Setting	Modify
	output voltage 2				
PF.39	HF-ACR proportional gain P2	0~65535	0~65535	1000	⊙
PF.40	HF-ACR integral gain I2	0~65535	0~65535	1000	○
PF.41	Slip compensation coefficient 2 of drive side	50~200	50~200	100%	○
PF.42	Slip compensation coefficient 2 of braking side	50~200	50~200	100%	○
PF.43	Torque upper limit current value 2	0.0~200	0.0~200	110%	⊙
PF.44	Motor overspeed point 2	0~200	0~200	110%	⊙
PF.45	Motor overtemperature 2	0~1	0~1	0	⊙
PF.46	Motor overtemperature threshold 2	0.0~60.0	0.0~60.0	40.0℃	⊙
PF.47	Motor overtemperature prewarning threshold 2	20.0~100.0	20.0~100.0	90%	⊙
PF.48	Motor temperature compensation enable 2	0~1	0~1	0	⊙
PF.49	Motor temperature compensation initial threshold 2	0.0~60.0	0.0~60.0	40.0℃	○
PF.50	Motor temperature compensation	0.0~200.0	0.0~200.0	100	○

Function Code	Name	Description	Setting Range	Factory Setting	Modify
	coefficient 2				
PF.51	Reserved	0~65535	0~65535	0	⊙
PF.52	Reserved	0~65535	0~65535	0	⊙
PF.53	Motor type 2	0~1	0~1	0	⊙
PF.54	Magnetic pole initial position 2	0.00~360.00	0.00~360.00	0	⊙
PF.55	Magnetic pole position amplitude gain 2	0.50~1.50	0.50~1.50	1	⊙
PF.56	C phase magnetic pole position bias 2	0~9999	0~9999	433	⊙
PF.57	D phase magnetic pole position bias 2	0~9999	0~9999	433	⊙
PP Group: Motorparameters 3					
PP.00	Speed control mode 3	0: Sensorless vector control 1: Vector control with PG 2: V/F control	0~2	1	⊙
PP.01	Maximum frequency 3	10.00~400.00Hz	10.00~400.00	50.00Hz	⊙
PP.02	Motor rated speed power 3	0.4~900.0kW	0.4~900.0	Depend on model	⊙
PP.03	Motor rated speed frequency 3	0.01Hz~400.00Hz	0.01~400.00	50.00Hz	⊙
PP.04	Motor rated speed3	1~36000rpm	1~36000	1460rpm	⊙
PP.05	Motor rated speed voltage 3	1~480V	1~480	380V	⊙
PP.06	Motor basic speed current 3	0.1~2000.0A	0.1~2000.0	Depend on model	⊙
PP.07	Motor rated speed	0.05~1.00	0.05~1.00	0.86	⊙

Function Code	Name	Description	Setting Range	Factory Setting	Modify
	power factor 3				
PP.08	Motor stator resistance 3	0.001~65.535Ω	0.001~65.535	Depend on model	○
PP.09	Motor rotor resistance 3	0.001~65.535Ω	0.001~65.535	Depend on model	○
PP.10	Motor leakage inductance 3	0.1~6553.5mH	0.1~6553.5	Depend on model	○
PP.11	Motor mutual inductance 3	0.1~6553.5mH	0.1~6553.5	Depend on model	○
PP.12	Current without load 3	0.01~655.35A	0.01~655.35	Depend on model	○
PP.13	Acceleration time 3	0.0~3600.0s	0.0~3600.0	20.0s	○
PP.14	Deceleration time 3	0.0~3600.0s	0.0~3600.0	20.0s	○
PP.15	Start section of acceleration S curve 3	0.1~50.0%	0.1~50.0	10.0%	◎
PP.16	End section of acceleration S curve 3	0.1~50.0%	0.1~50.0	10.0%	◎
PP.17	Start section of deceleration S curve 3	0.1~50.0%	0.1~50.0	10.0%	◎
PP.18	End section of deceleration S curve 3	0.1~50.0%	0.0~50.0	10.0%	◎
PP.19	Encoder type selection	0: Increment encoder 1: SIN/COS encoder 2: UVM encoder	0~2	0	◎
PP.20	Encoder pulse counting 3	1~65535	1~65535	1000	◎
PP.21	Encoder direction	0: Forward	0~1	0	◎

Function Code	Name	Description	Setting Range	Factory Setting	Modify
	3	1: Reverse			
PP.22	Carrier frequency 3	1.0~16.0kHz	1.0~16.0	Depend on model	○
PP.23	ASR proportional gain K_p3	0~100	0~100	20	○
PP.24	ASR integral time K_i3	0.01~10.00s	0.01~10.00	0.50s	○
PP.25	Low speed detecting filter time 3	0.000~1.000s	0.000~1.000	0.000s	○
PP.26	ASR switching point 3	0.00Hz~PP.30	0.00~PP.30	5.00Hz	○
PP.27	ASR proportional gain K_p3	0~100	0~100	25	○
PP.28	ASR integral time K_i2	0.01~10.00s	0.01~10.00	1.00	○
PP.29	High speed detecting filter time 3	0.000~1.000s	0.000~1.000	0.000s	○
PP.30	ASR switching point 2	PP.26~P0.03	PP.26~P0.03	10.00Hz	○
PP.31	ACR proportional gain $P3$	0~65535	0~65535	500	○
PP.32	ACR integral gain $I3$	0~65535	0~65535	500	○
PP.33	Motor weak magnetic 3	0.1~2.0	0.1~2.0	1.0	◎
PP.34	Motor minimum weak magnetic 3	10.0~80.0%	10.0~80.0	50.0%	◎
PP.35	The proportion of weak magnetic 3	0~65535	0~65535	0	◎
PP.36	Low-frequency threshold of	0~10	0~10	2	◎

Function Code	Name	Description	Setting Range	Factory Setting	Modify
	restraining oscillation 3				
PP.37	High-frequency threshold of restraining oscillation 3	0~10	0~10	0	☉
PP.38	Maximum motor output voltage 3	PP.05~550V	PP.05~550	380V	☉
PP.39	HF-ACR proportional gain P3	0~65535	0~65535	1000	☉
PP.40	HF-ACR integral gain I3	0~65535	0~65535	1000	○
PP.41	Slip compensation coefficient 3 of drive side	50~200	50~200	100%	○
PP.42	Slip compensation coefficient 3 of braking side	50~200	50~200	100%	○
PP.43	Torque upper limit current value 3	0.0~200	0.0~200	110%	☉
PP.44	Motor overspeed point 3	0~200	0~200	110%	☉
PP.45	Motor overtemperature 3	0~1	0~1	0	☉
PP.46	Motor overtemperature threshold 3	0.0~60.0	0.0~60.0	40.0℃	☉
PP.47	Motor overtemperature prewarning threshold 3	20.0~100.0	20.0~100.0	90%	☉
PP.48	Motor temperature	0~1	0~1	0	☉

Function Code	Name	Description	Setting Range	Factory Setting	Modify
	compensation enable 3				
PP.49	Motor temperature compensation initial threshold 3	0.0~60.0	0.0~60.0	40.0℃	○
PP.50	Motor temperature compensation coefficient 3	0.0~200.0	0.0~200.0	100	○
PP.51	Reserved	0~65535	0~65535	0	◎
PP.52	Reserved	0~65535	0~65535	0	◎
PP.53	Motor type 3	0~1	0~1	0	◎
PP.54	Magnetic pole initial position 3	0.00~360.00	0.00~360.00	0	◎
PP.55	Magnetic pole position amplitude gain 3	0.50~1.50	0.50~1.50	1	◎
PP.56	C phase magnetic pole position bias 3	0~9999	0~9999	433	◎
PP.57	D phase magnetic pole position bias 3	0~9999	0~9999	433	◎



SHENZHEN INVT ELECTRIC CO., LTD.

ADD: No.4 Building , Gaofa Industrial Park , Longjing , Nanshan
District, Shenzhen, China, 518055

Tel: 86-755-86312856 Fax: 86-755-86312832

E-mail: overseas@invt.com.cn <http://www.invt.com>